



# TSP 128



## Operator panel with integrated PLC

- Graphic LCD 240x128
- High speed (2msec. standard cycle time)
- Contact programming with Ladder language
- Function for Recipe management , P.I.D. Regulator , Print etc ...
- Touch Screen

ELECTRIC CHARACTERISTICS	
Power supply voltage	Min 20Vcc ; Max 26 Vcc Min 15 Vac ; Max 21 Vac
Current Consumption	Under 200mA without loads
Microprocessor	Hitachi H8S/2145B @ 20MHz
Program Memory	64 KB
Pages Memory	1 MB
E <sup>2</sup> PROM	64 KB
Cycle Time	Programmable (min 1 msec.)
Digital Inputs	16 digital inputs PNP at 24 Volts of which 4 fast input (5KHz for encoder reading) with programmable anti-noise filter (value 1...16)

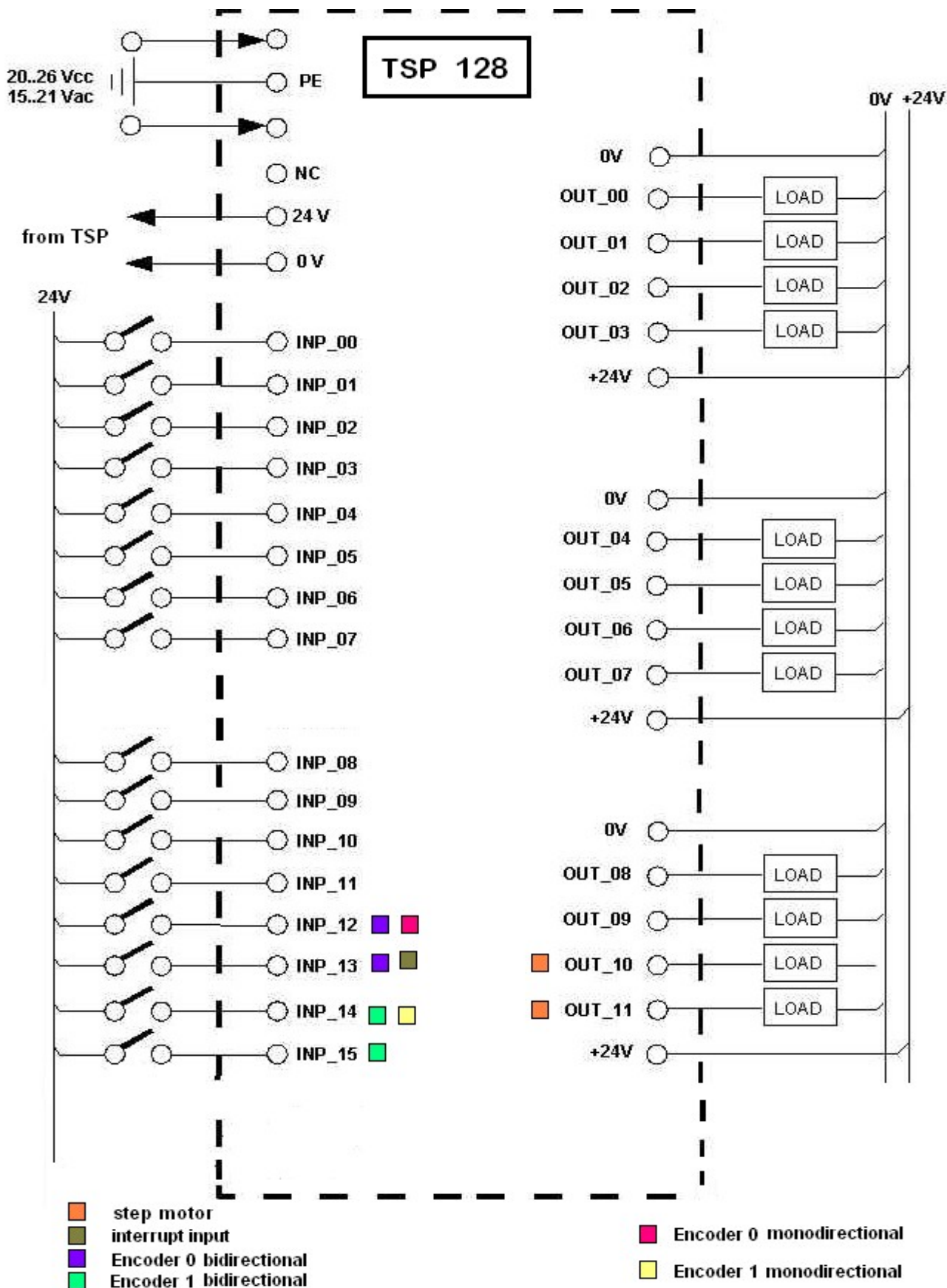



<b>Analog Inputs</b>	<b>4 configurable analog inputs, 10bits configurable for voltage, current, PT100 or TMC .</b>
<b>Digital Outputs</b>	<b>12 outputs PNP 24 V at 500 mA</b>
<b>Analog Outputs</b>	<b>2 analogic outputs +/- 10V 12 bit [0...4045] and 2 analogic outputs 0...+10V con risoluzione 8 bit [0...255]</b>
<b>Plugged RAM</b>	<b>79 words any 100 msec automatically copy into plugged RAM (for a term of 1 year)</b>
<b>RTC</b>	<b>Extern real time clock with plugged calendar and clock with rechargable battery . (for a term of 1 year)</b>
<b>Serial Lines</b>	<p><b>3 serial lines (COM 0, COM 1 e COM 2) with the possibility of replace COM 1 with Ethernet.</b></p> <p><b>COM 0 :</b> It could be used in RS232 , RS485 or RS422 with many different standard communication protocols for connect other devices (I/O expansions , termoregulators , inverters or network connection) .</p> <p><b>COM 1 :</b> It is RS232 mode and it's use like COM0 , besides for upload applications or operative system .</p> <p><b>COM 2 :</b> It could be used in RS485 or RS422 mode with many different standard communication protocols for connect other devices (I/O expansions , termoregulators , inverters or network connection) .</p>

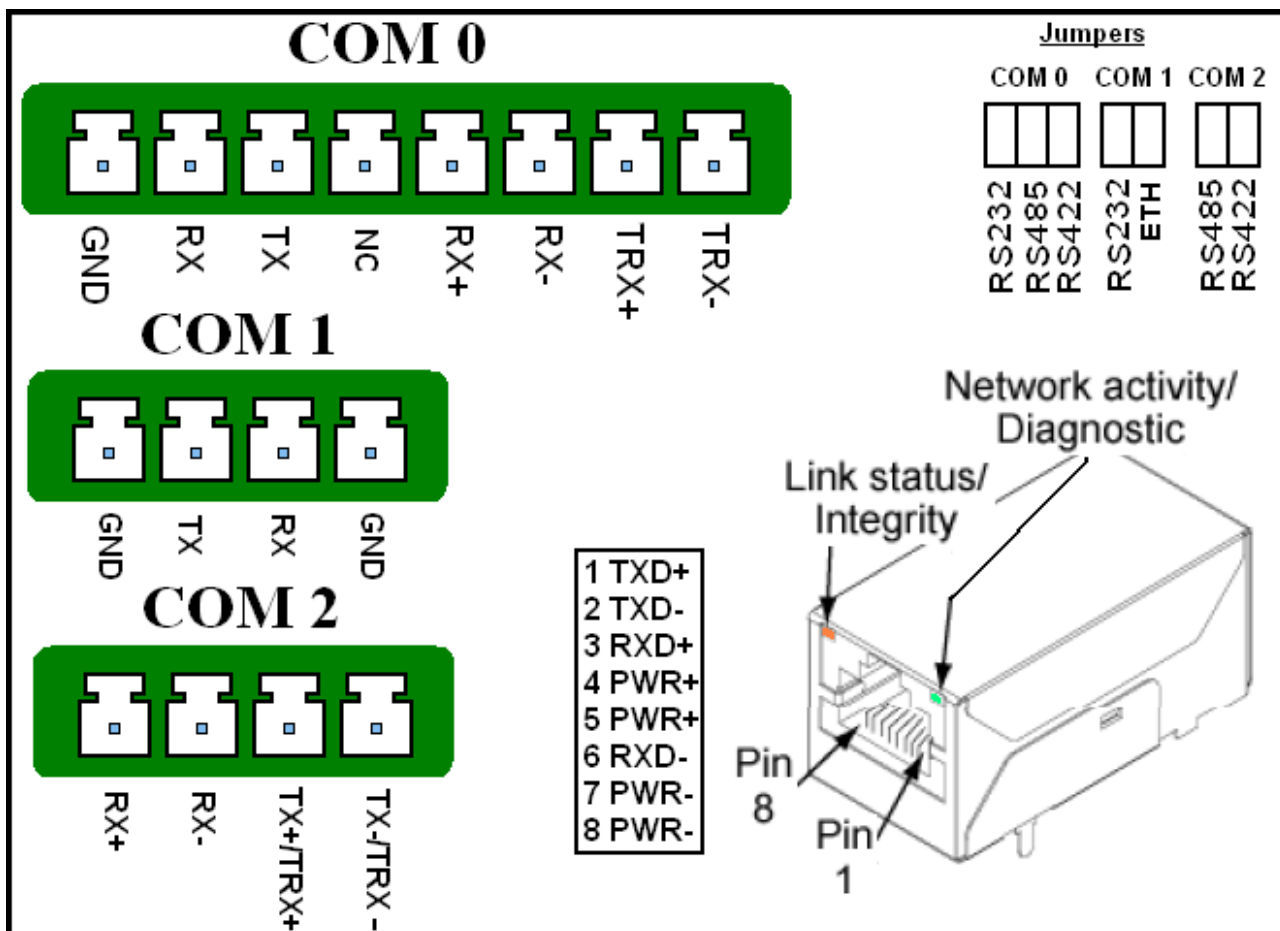

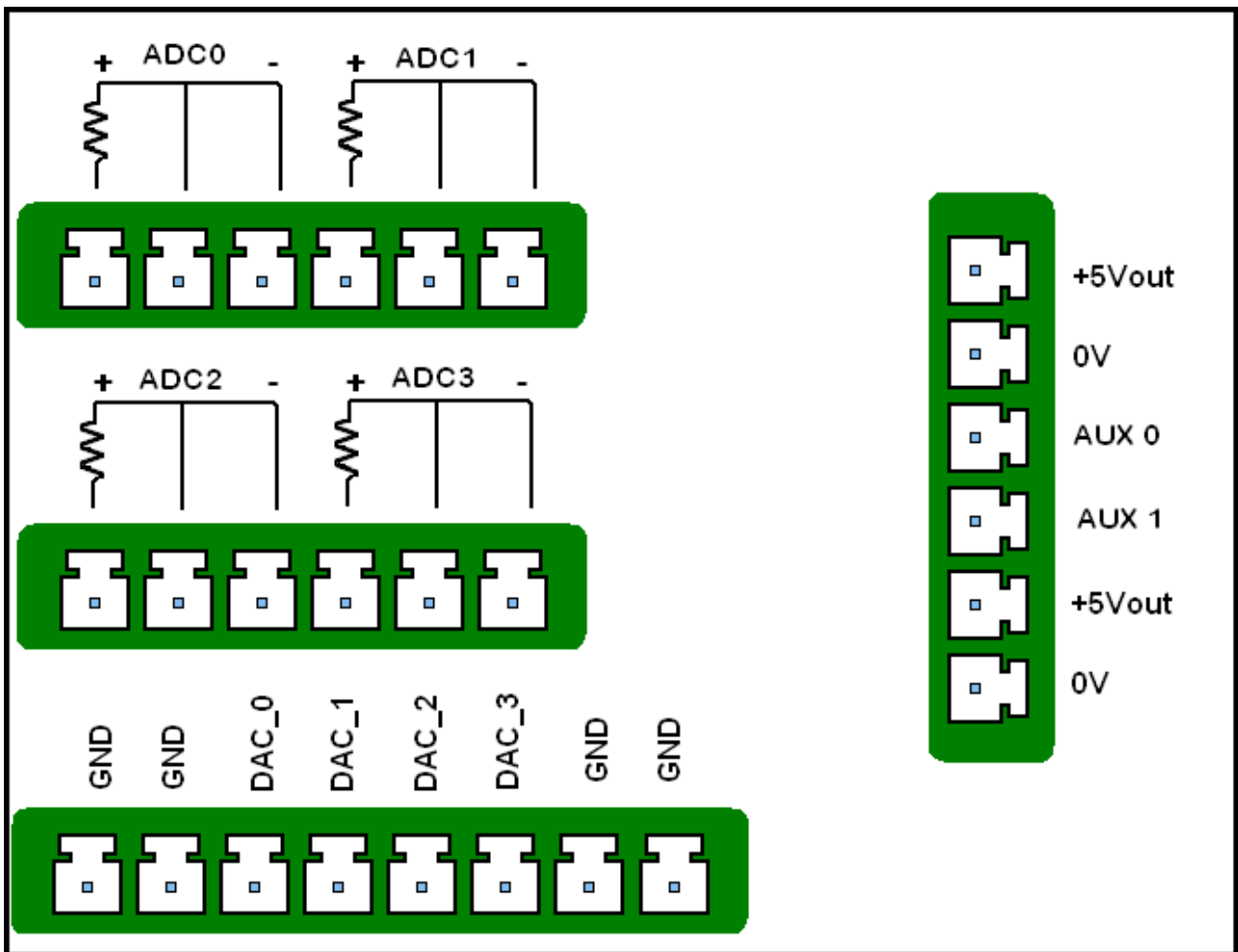



MECHANICS CHARACTERISTICS	
Temperature Range	from -10 °C to +70 °C
Humidity Range	from 10 to 90% (non-condensing)
Operating Atmosphere	Without corrosive gas
Noise Immunity	According to rules in force
Fixing System	Four M4 pegs
Weight	1 Kg
Keyboard	Touch screen with high resolution .
Display	Graphic display 240X128 (40 characters for 16 lines) backlight LED . 4 signalling LEDS.
Size	Front view 208x148 mm , Depth 81 mm

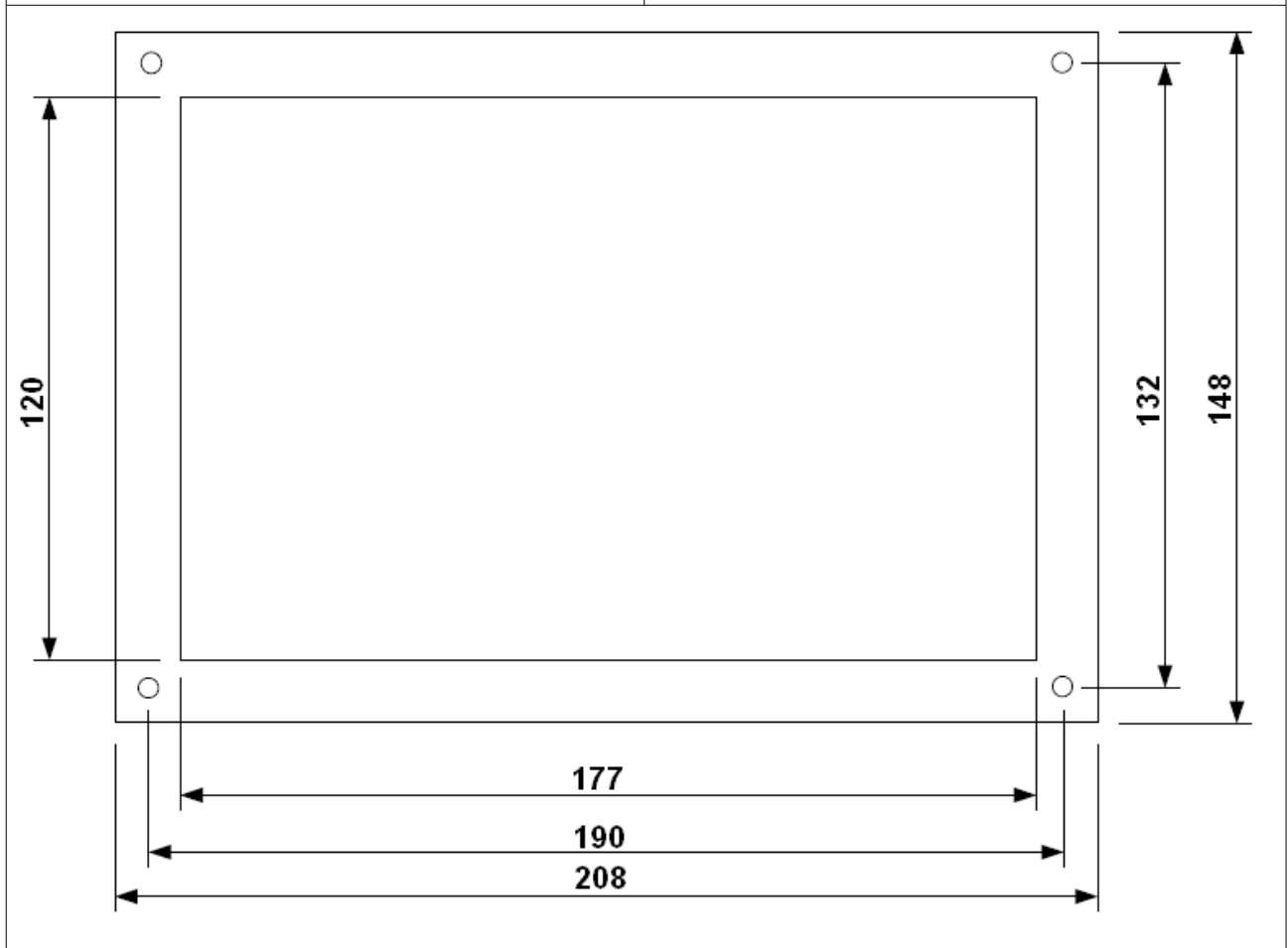

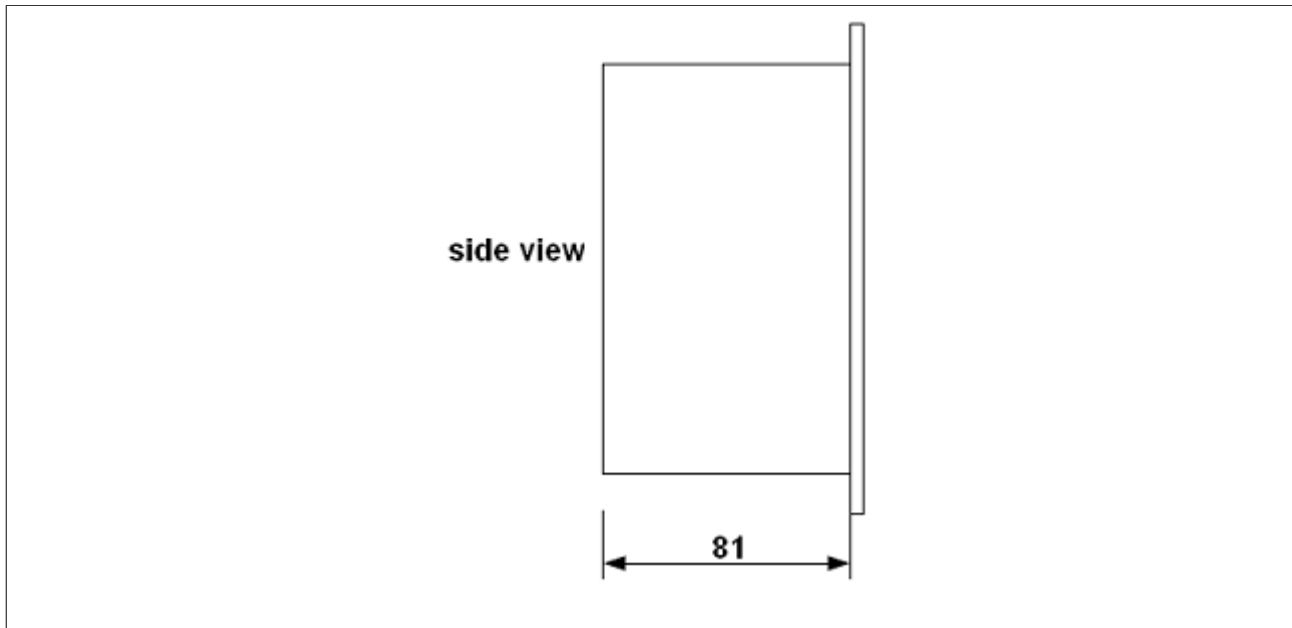

**SOFTWARE CHARACTERISTICS**

<b>Programming Languages</b>	<b>AWL / Ladder</b>
<b>Timers</b>	<b>64 timers with 16 bits and resolution 1/100 sec . 32 configurable timers one by one like excitation delay or disexcitation delay and 32 only excitation timers . 8 timers free running with 1 msec resolution enabled one by one with system flag .</b>
<b>Counters</b>	<b>32 counters with 16 bits configurable one by one like incremental or decremental .</b>
<b>Data Memory</b>	<b>2048</b>



<b>Developed Functions</b>	<ul style="list-style-type: none"><li>- <b>Week Programming</b></li><li>- <b>Recipe Management</b></li><li>- <b>Step Motor Management</b></li><li>- <b>Encoders Management</b></li><li>- <b>P.I.D. Temperature's Regulator</b></li><li>- <b>Forwarding/Reception SMS Messages</b></li></ul>
<b>Memory area check in real time mode on data table ( Debug )</b>	●
<b>Ladder's subroutines Import/Export</b>	●
<b>Contact and variable check in real time mode on ladder ( Debug Online )</b>	●