



TK04ACS



DATA SHEET

rev. 2.9
12 December 2023

Kernel Sistemi
Kernel Sistemi s.r.l. , via Vignolese n. 1138
41126 Modena - ITALY
Tel. 059 469 978 - Fax 059 468 874
www.kernelgroup.it

INDEX

- 1 INTRODUCTION..... 3**
- 1.1 Manual Operation.....3
- 1.2 Automatic Operation.....3
- 2 HARDWARE CHARACTERISTICS.....4**
- 2.1 Electric Characteristics.....4
- 2.2 Mechanics Characteristics.....4
- 2.3 I/O Connections.....5
- 3 GENERAL NOTES..... 6**
- 3.1 DIP-SWITCHES.....6
- 3.2 Communication.....6
- 3.3 RS485 Communication cable.....7
- 3.4 Box Dimensions + Cables.....8
- 3.5 Memory.....9
- 3.6 Motor Test.....10
- 3.7 Assembly.....10
- 3.8 Motor Connections.....11
- 3.9 Keyboard.....11
- 4 CONTACTS..... 12**

Attention

*The information contained in this document may change without notice.
Therefore, please check our website (www.kernelgroup.it) regularly
and always download the latest version available.*

1 INTRODUCTION

The TK... device is a tracker for single-axis solar trackers. It has to be installed integral with the panel supports to control the east-west movement in order to maximize the panels' exposure to solar radiation during the day.

The device is plugged into an RS485 communication network of which it becomes a slave node. This means that it expects to receive commands from a master device (coordinator) that will have the task of managing the network of devices.

Each tracker is equipped with a motor driver that moves the axis, as well as an inclinometer that detects the inclination of the panels with respect to the horizontal plane. Moreover, the inclinometer receives the set point position from the network master and drives the motor to reach and maintain it, returning the operating status and any alarms to the master.

The tracker is equipped with a small keypad featuring three keys and two signalling LEDs. The MAN/AUTO key allows selection between manual or automatic operation.

1.1 Manual Operation

Manual operation is used in the event of plant maintenance to manually control the movement of the panels, and it is signalled by a fast flashing of the LED. The arrow keys control UP or DOWN movement, and pressing one of the keys starts the motor until it is released.

1.2 Automatic Operation

Automatic operation is performed during normal use of the plant, it is signalled by a slow flashing of the LED, and pressing the arrow keys has no effect. The tracker receives the set point position from the master and drives the motor to reach and maintain it.

The tracker is equipped with various safety mechanisms to prevent damage to the motor or structure, in particular :

- two limit switches (IN and OUT) that interrupt the movement if they are activated
- two software limit switches: the tracker does not accept set points beyond these limits
- encoder inputs : if activated, they can detect any failure to start the motor
- timeout at start : further control of actual motor start
- positioning timeout : signals an alarm if the motor does not reach the position within the preset time
- position error : signals an alarm if the set point position is not reached

Description of STATUS bits

The tracker returns a **STATUS** variable to the master that contains the current status of the device and the presence of any alarms (see paragraph 3.5 >> STATUS).

Description of the COMMAND bits

The tracker can also receive particular commands from the master in a **COMMAND** word (see paragraph 3.5 >> COMMAND).

Description of configuration variables

Various parameters can be set to configure the device and adapt it to different plant requirements (see paragraph 3.5).

2 HARDWARE CHARACTERISTICS

This chapter describes the hardware characteristics of TK04ACS :

2.1 Electric Characteristics

ELECTRIC CHARACTERISTICS	
Power supply voltage	230 Vac
Maximum Permitted Power Supply	230 Vac
Current Consumption	x
Microprocessor	ARM GD F303
Digital Inputs	4 digital inputs
Analog Inputs	x
Digital Outputs	x
Analog Outputs	2 outputs to manage an engine
Serial Lines	1 Serial Line : RS 485 Supports the communication protocols : KERNEL / KNP and MODBUS RTU
Led	2 leds on the keyboard
Addressing	12 Dip-switches (of which only 8 for the addressing from 1 to 255)

2.2 Mechanics Characteristics

MECHANICS CHARACTERISTICS	
Temperature Range	From -10 ^C to +70^C
Humidity Range	From 10 % to 90 % (non-condensing)
Operating Atmosphere	Without corrosive gas
Noise Immunity	According to rules in force
Box Protection degree	IP66 / IP69
Box Weight	n.d.
Keyboard	3 buttons (MAN/AUTO - UP Arrow - DOWN Arrow)
Display	No Display

2.3 I/O Connections

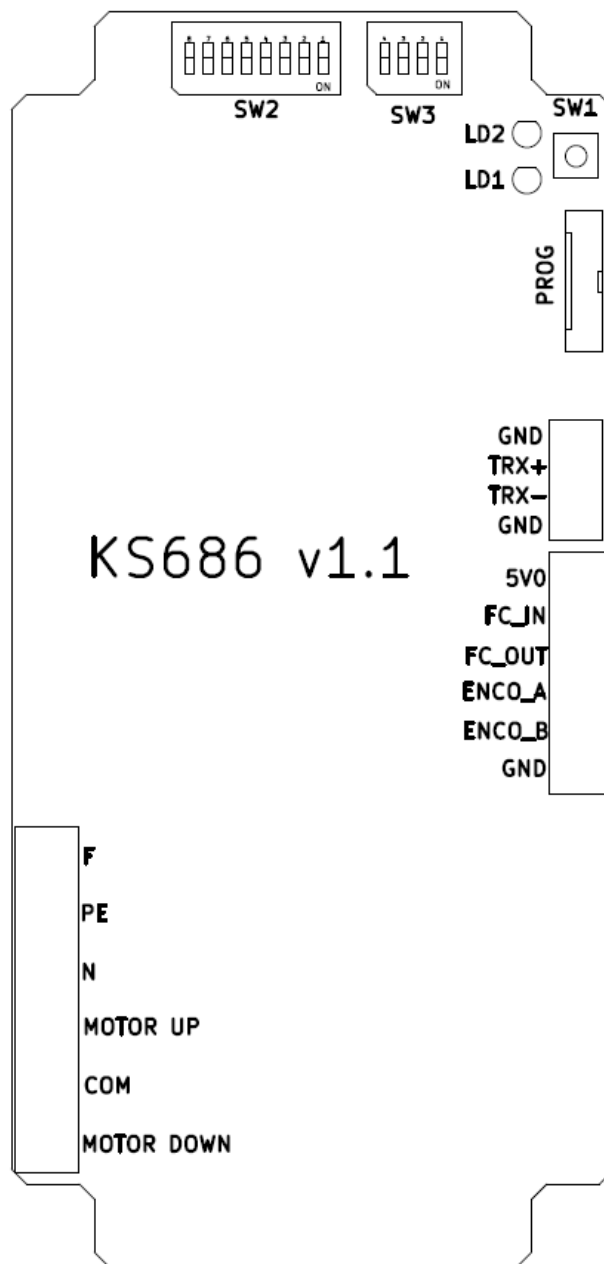

TK04ACX

Where :

TK = tracker

04 = rated current 04 Amps

AC = 230 Vac nominal power supply

Where X can be :

S = Serial RS_485

W = Wireless sub-giga mesh (Advanticsys e-108 module)

L = Wireless sub-giga LoRA (HopeRF RFM95W module)

3 GENERAL NOTES

3.1 DIP-SWITCHES

You can configure for each TK04ACS its own node address, baud rate and protocol, through the 8 suitable dip-switches (see hardware characteristics and the following figure).

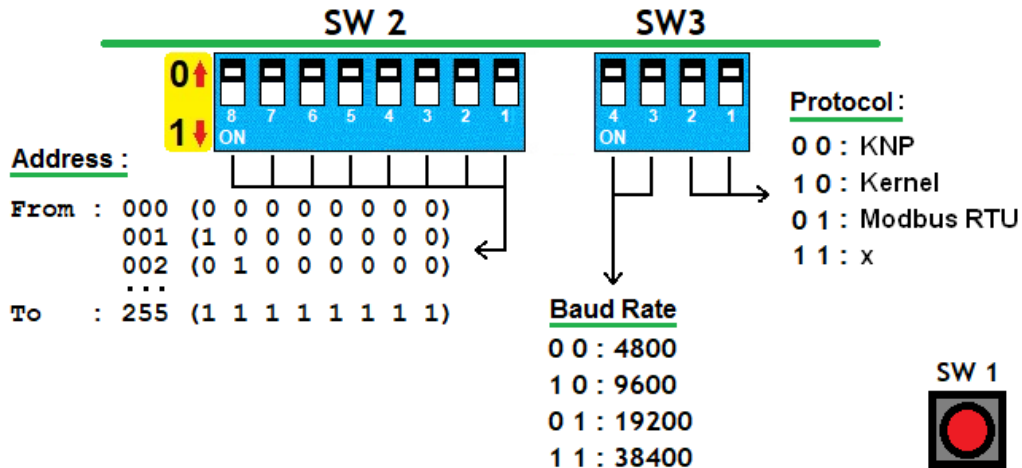

Here are some examples that help to understand :

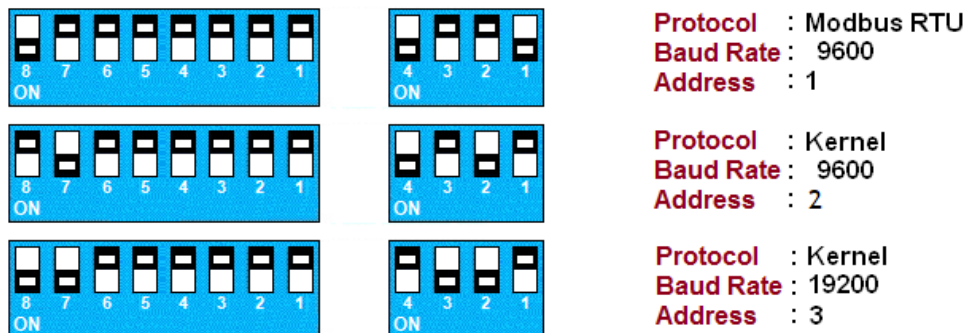

3.2 Communication

The serial communication occurs only via RS 485. It will be necessary to set the Protocol and Baud Rate (4800 / 9600 / 19200 / 38400, N, 8, 1) on the external device.

With the dip-switches 1 and 2 of SW3 you select the COMMUNICATION PROTOCOL and with the dip-switches 3 and 4 of SW3 you choose the BAUD RATE; according to the protocol set with the dip-switches, you need to select the corresponding protocol (within the PLC project) in the COM used between PLC and expansions. Also in this case it's necessary to open the PLC project to select the correct protocol :

DIP-SWITCH 1 and 2 of SW3	- PLC Protocol
00 = KNP	- KNP
01 = KERNEL Protocol	- KERNEL
10 = MODBUS RTU Protocol	- RTU MASTER
11 = x	- x

3.3 RS485 Communication cable

Everything about the RS485 connection, must meet certain features :

Maximum cable length

it must be no longer than 600 mt (it means the entire line length, and not the connection between two nodes)

Technical characteristics of the cable to use

It must be a three-wire cable 3 x 0.75 mm

How to do the RS485 connection

The RS485 connection must be a three wires connection (TX+, TX- and GND) with a shielded cable. The cable shield must be leaved float, it means that the shield must be not connected neither one side nor the other one.

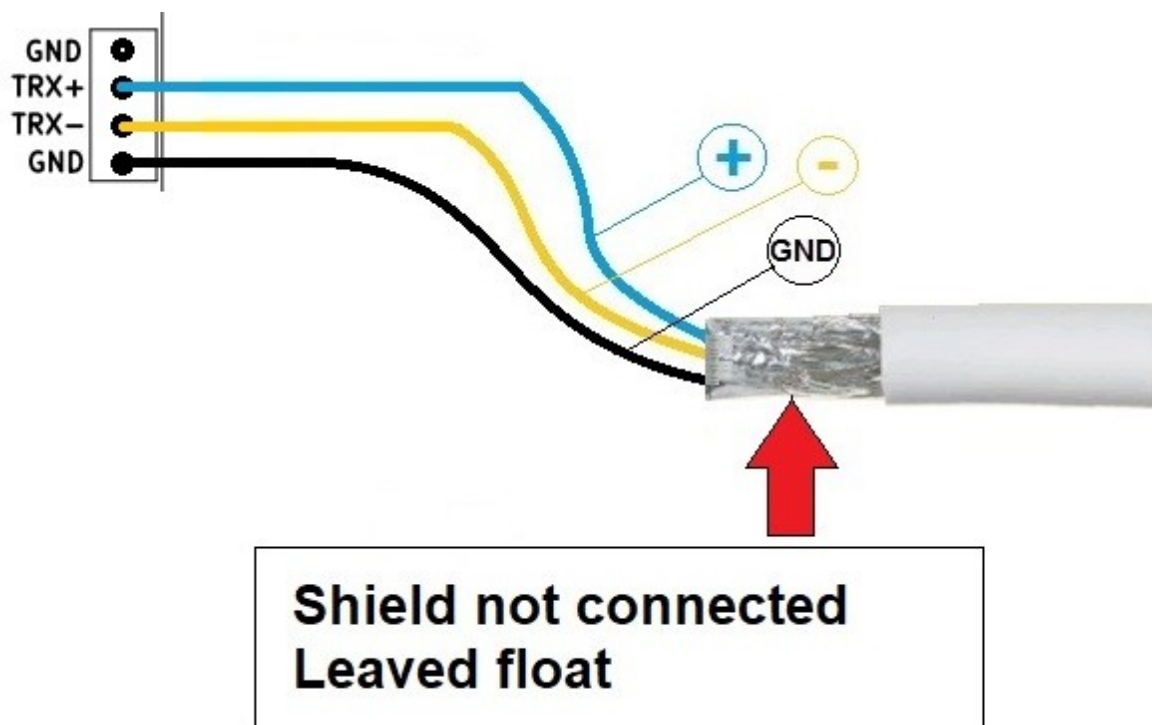

Notes

1. You can connect up to a maximum of 25-30 trackers for each RS 485 COM port of the PLC.
2. You may need to connect the 120 Ohm termination resistor.
3. The maximum communication distance is 600 meters (maximum distance means the complete distance of the network, not the distance between two nodes).

3.4 Box Dimensions + Cables

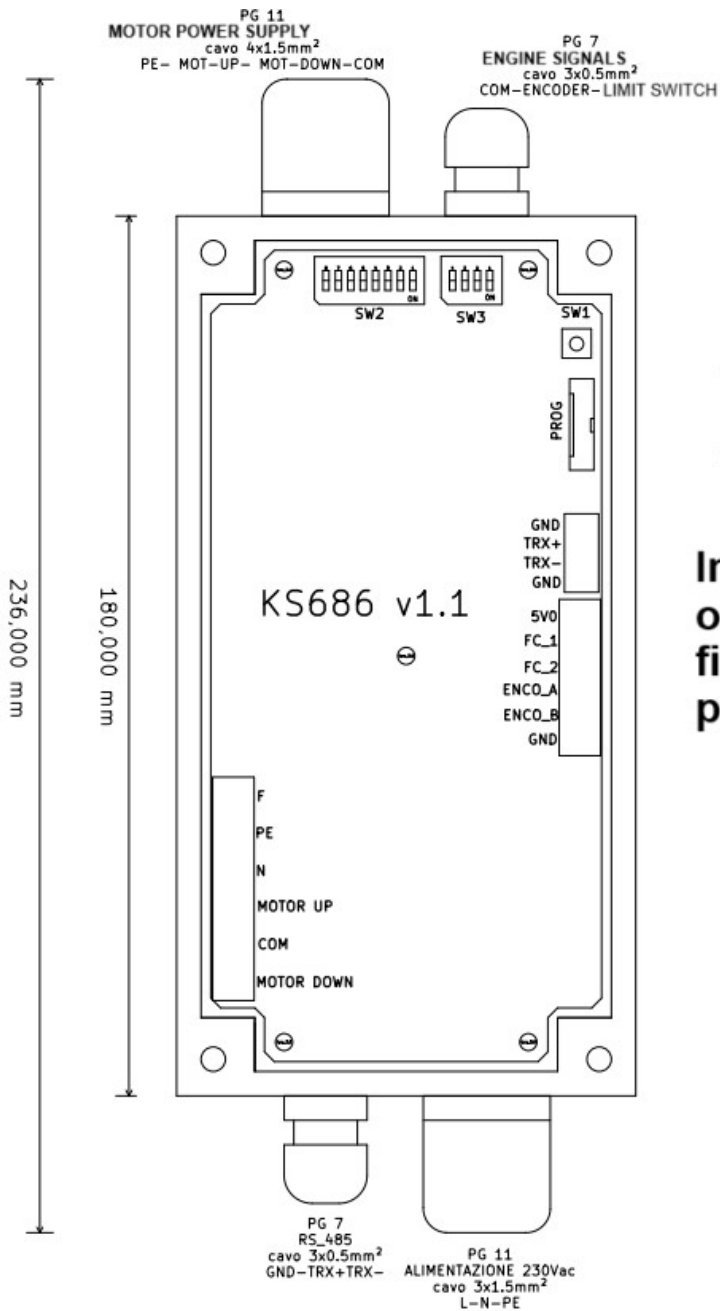

BOTTOM VIEW OF THE BOX

Inside, on the inside of the cover, you will find the card positioned like this

3.5 Memory

By default, the operating mode set is : **AUTOMATIC**.

In this mode it is necessary to write the **SET POINT** in **DATA.08** and the motor will be piloted in order to set and maintain the inclination (by an Inclinomater) written in this register.

In **DATA.24** it is always possible to read the current position in degrees.

In **DATA.136** and **DATA.137** there are, respectively, the **MINIMUM** limit and the **MAXIMUM** limit beyond which the new set point is not accepted.

The **MANUAL** functioning mode, on the other hand, is activate by resetting **Bit 0** and **Bit 1** of **DATA.01** (**COMMANDS**).

In this mode, just activate **Bit 2** of **DATA.01** (**COMMANDS**) to go **UP** or **Bit 3** of **DATA.01** (**COMMANDS**) to go **DOWN**.

The TK04ACS has some internal 16 bit memory locations (word) called "REGISTERS". Because each REGISTER is composed by 16 bits, its maximum value will be 65535.

MODBUS Register	Description
DATA.00	STATUS - READ ONLY Bit 01 + Bit 00 : Operating Mode 0 - 0 = MANUAL 0 - 1 = AUTOMATIC 1 - 0 = REMOTE 1 - 1 = x Bit 02 : Indicates if it is going UP Bit 03 : Indicates if it is going DOWN Bit 04 : FTC IN Bit 05 : FTC OUT Bit 06 : Encoder A Bit 07 : Encoder B Bit 08 : Encoder signal missing ERROR Bit 09 : Engine not started ERROR Bit 10 : Movement timeout ERROR Bit 11 : Motor stopped out of position ERROR Bit 12 : V Batt OK
DATA.01	COMMANDS - WRITE ONLY Bit 00 + Bit 01 : Operating Mode Bit 02 : GO UP Bit 03 : GO DOWN
DATA.08	SET POINT : Inclination value to be set in degrees, An engine is piloted in order to set and maintain the inclination (using an Inclinomater) written in this register.
DATA.24	Current position in degrees
DATA.136	MINIMUM limit beyond which the new set point is not accepted
DATA.137	MAXIMUM limit beyond which the new set point is not accepted
DATA.138	V_BAT_MIN : minimum battery voltage
DATA.139	TIM_ENCO : timout encoder [1/10] sec (0 = Disabled)
DATA.140	TIM_START : start timeout (0 = Disabled)

MODBUS Register	Description
DATA.141	MOTOR TIMEOUT : positioning timeout (0 = Disabled)
DATA.142	POSITION DELTA : position error threshold (0 = Disabled)

3.6 Motor Test

Placing all the DIP-SWITCHES on OFF (0) and starting the TK04ACS you access the TEST mode. In this mode, the 2 LEDs flash alternately and it is possible to test the functioning of the motor.

Pressing the button :

- 1st press of the button : UP Engine
- 2nd press of the button : STOP
- 3rd press of the button : Motor DOWN
- 4th press of the button : STOP

To quit the MOTOR TEST just switch off the TK04ACS, reposition the DIP-SWITCHES in the desired position and restart the board.

3.7 Assembly

Barra sostegno pannello

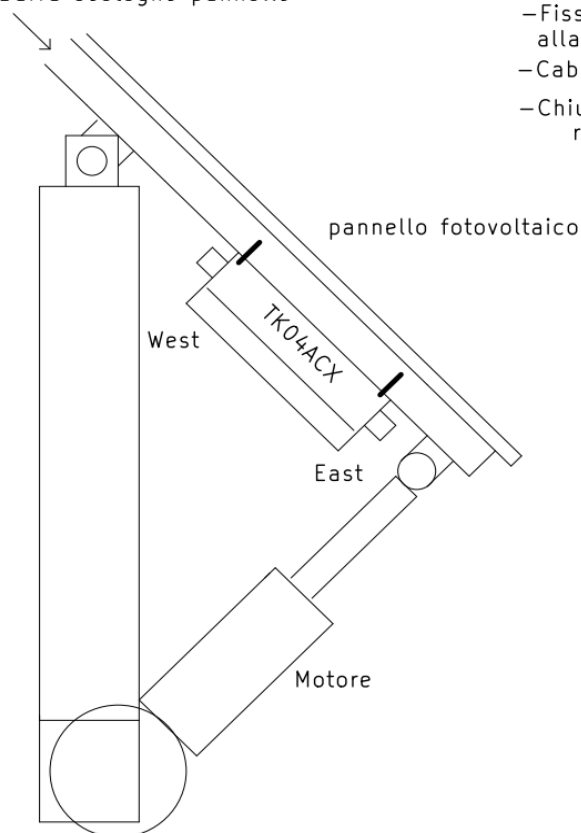

- Aprire la scatola TK04ACX
- Fissare la parte inferiore con i pressacavi, alla barra sostegno pannello,utilizzando viti NON fornite
- Cablare i morsetti, facendo passare i collegamenti nei pressacavi
- Chiudere la scatola TK04ACX, prendendo come riferimento i relè statici, come in figura

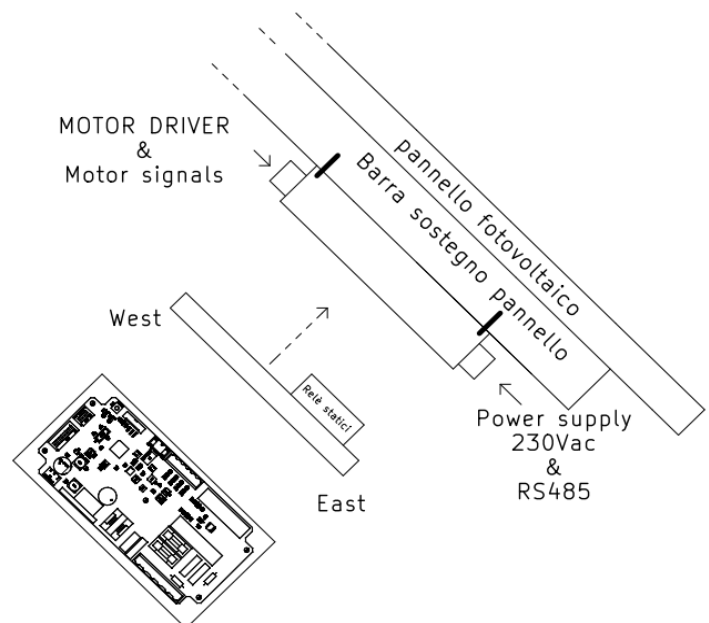

3.8 Motor Connections

COLLEGAMENTI TK04ACX

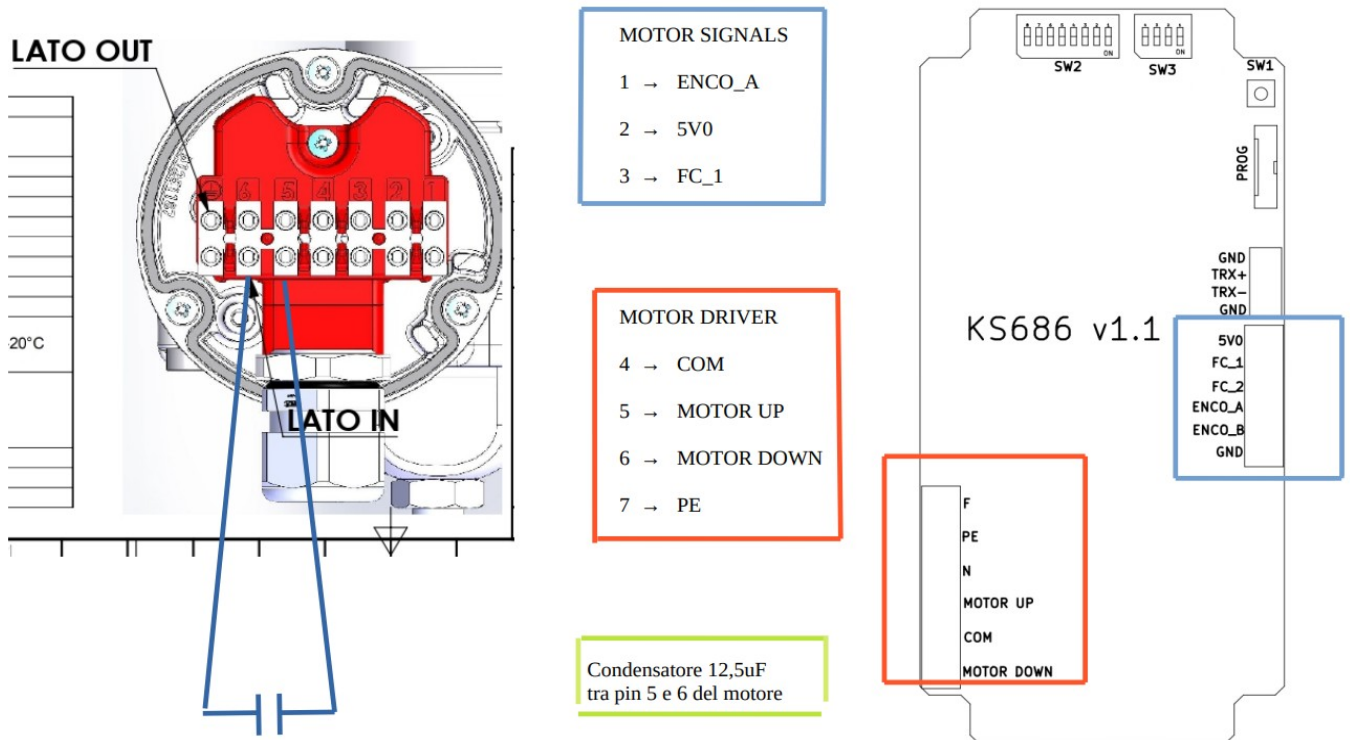

3.9 Keyboard

The "MAN / AUTO" key sets the operating mode of the TK04ACS tracker :

AUTO : (it is in AUTOMATIC at startup)

The LED above the key flashes slowly (1 sec. ON / 1 sec. OFF).

The DATA.08 is used as Set Point :

DATA.08	SET POINT : Inclination value to be set in degrees, An engine is piloted in order to set and maintain the inclination (using an Inclinometer) written in this register.
----------------	--

Pressing the button, switches to MANUAL mode :

The LED above the key flashes quickly.

With the 2 arrow keys you can set the direction of movement (UP / DOWN)

COM LED :

If there is no serial communication, the COM LED flashes slowly.

If communication is active, the COM LED lights up with each packet received via serial port.

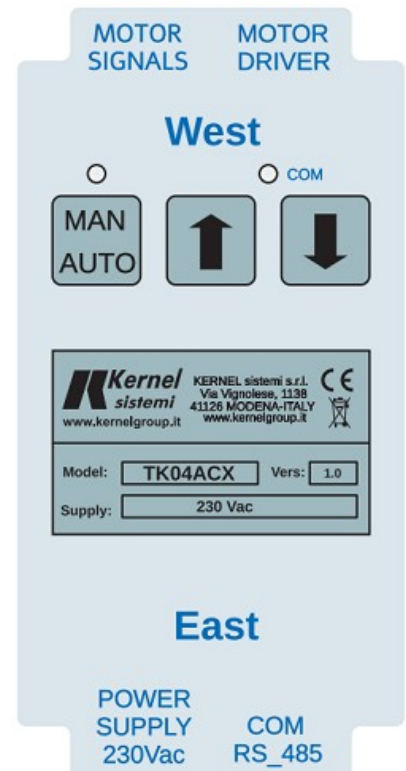

4 CONTACTS

GENERAL

Tel: 059 469978
website: www.kernelgroup.it
e-mail: info@kernelgroup.it

COMMERCIAL

Sig.ra Linda Mammi
Tel: 059 469978 Int. 207
e-mail: sales@kernelgroup.it
Skype: mammi.kernel

ADMINISTRATION

Sig.ra Paola Morandi
Tel: 059 469978 Int. 201
e-mail: amministrazione@kernelgroup.it
Skype: morandi.kernel

PURCHASING and PRODUCTION

Sig. Stefano Catuogno
Tel: 059 469978 Int. 204
e-mail: produzione@kernelgroup.it
Skype: catuogno.kernel

TECHNICAL OFFICE

Sig. Alessandro Muratori
Tel: 059 469978 Int. 205
e-mail: alessandro.muratori@kernelgroup.it
Skype: muratori.kernel

Support
Tel: 059 469978 Int. 209
e-mail: support@kernelgroup.it
Skype: support.kernel

Sig. Morisi Luca
e-mail: luca.morisi@kernelgroup.it
Skype: morisi.kernel

Kernel Sistemi
Kernel Sistemi s.r.l. , via Vignolese n. 1138
41126 Modena - ITALY
Tel. 059 469 978 - Fax 059 468 874
www.kernelgroup.it