



DMX 16



Operator panel with integrated PLC

- Fixing system on din rail
- High speed (2msec. standard cycle time)
 - Contact programming with Ladder language
- Function for Recipe management , P.I.D. Regulator , Print etc ...

ELECTRIC CHARACTERISTICS

Power supply voltage	Min 20 Vcc ; Max 26 Vcc Min 15 Vac ; Max 21 Vac
Current Consumption	Under 50mA without loads
Microprocessor	Hitachi H8S/2145B @ 20MHz
Program Memory	64 KB
Pages Memory	64 KB
E²PROM	64 KB
Cycle Time	Programmable (minimum 1 msec.)



Digital Inputs	8 digital inputs PNP 24 Volts of which 4 fast input (1KHz for encoder reading) with programmable anti-noise filter (value 1..16)
Analog Inputs	No analogic inputs
Digital Outputs	8 relay outputs 24V or 12V , 2A for any common
Analog Outputs	No analog outputs
Plugged RAM	79 words any 100 msec automatically copy into plugged RAM (for a term of 1 year)
RTC	Extern real time clock with plugged calendar and clock with rechargeable battery . (for a term of 1 year)

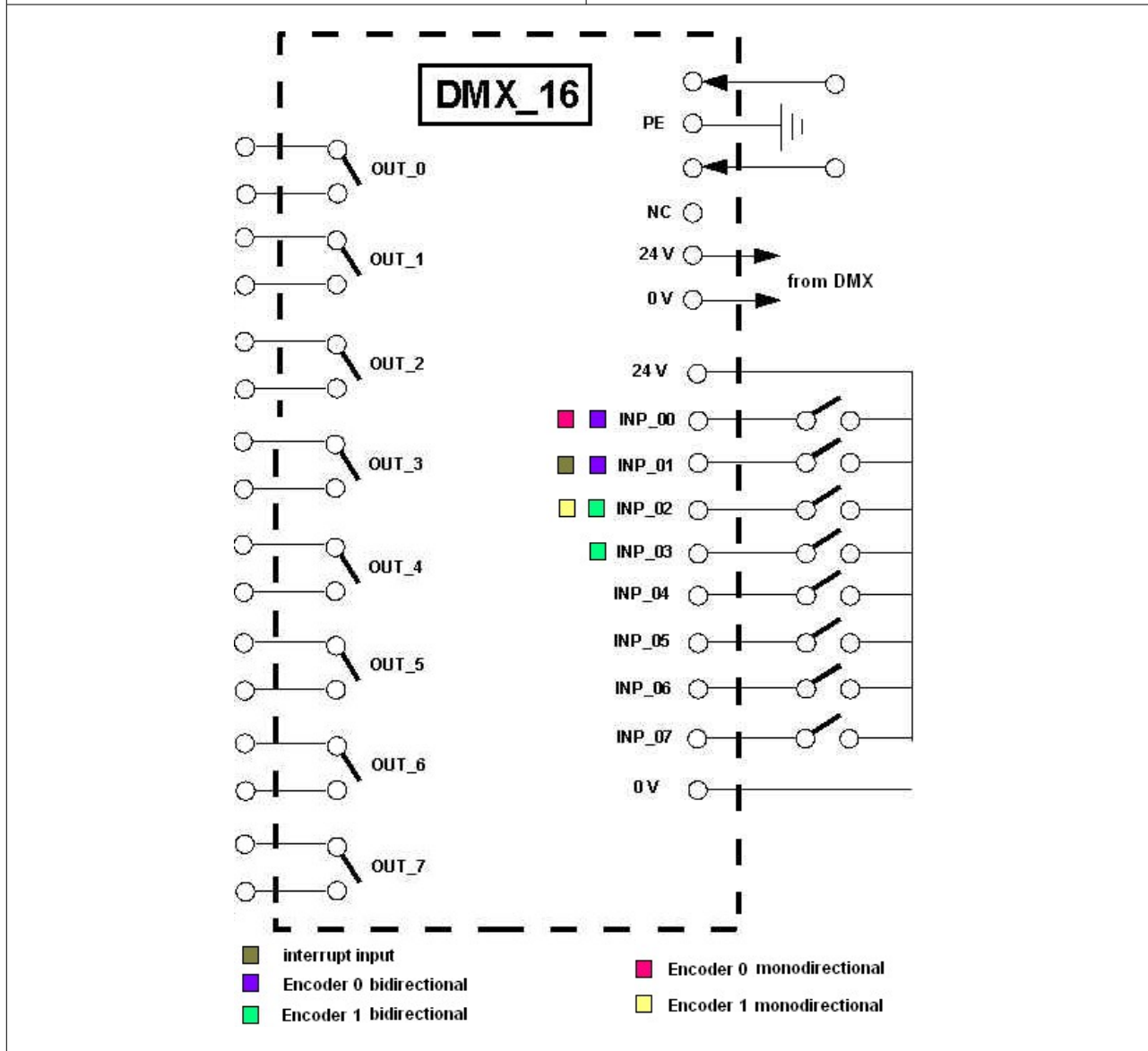

Serial Lines

2 serial lines (COM 0 , COM 1) .

COM 0 : It could be used in RS232 , RS485 or RS422 with many different standard communication protocols for connect other devices (I/O expansions , termoregulators , inverters or network connection) .

COM 1 : It could be used in RS232 or RS485 mode and it's use like COM0 , besides for upload applications or operative system .

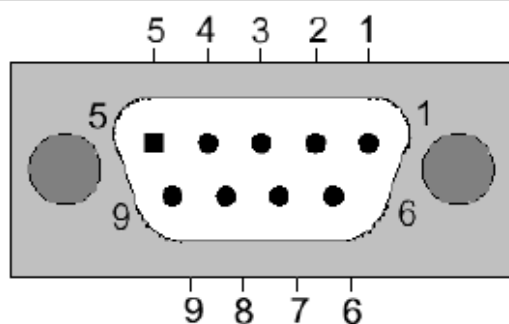

COM 1

RS232	RS485
2 RX	1 TRX+
3 TX	6 TRX-
5 GND	

Jumpers

COM 0

RS422	<input type="checkbox"/>
RS485	<input type="checkbox"/>
RS232	<input type="checkbox"/>

COM1

RS 485	<input type="checkbox"/>
RS232	<input type="checkbox"/>

COM 0

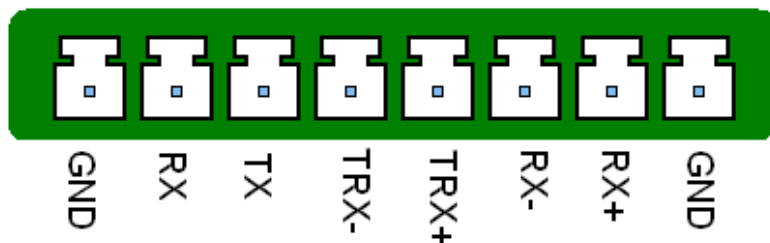

COM 0

RS232	RS422	RS485
2 RX	7 RX+	5 TRX+
3 TX	6 RX-	4 TRX-
1 GND	5 TX+	
	4 TX-	
	8 GND	

MECHANICS CHARACTERISTICS

Temperature Range	from -10 °C to +70 °C
Humidity Range	from 10 to 90% (non-condensing)
Operating Atmosphere	Without corrosive gas
Noise Immunity	According to rules in force
Fixing System	On din rail
Weight	450 gr
Keyboard	4 dedicated buttons
Display	Alphanumeric display 16 characters on 2 rows , backlight LED

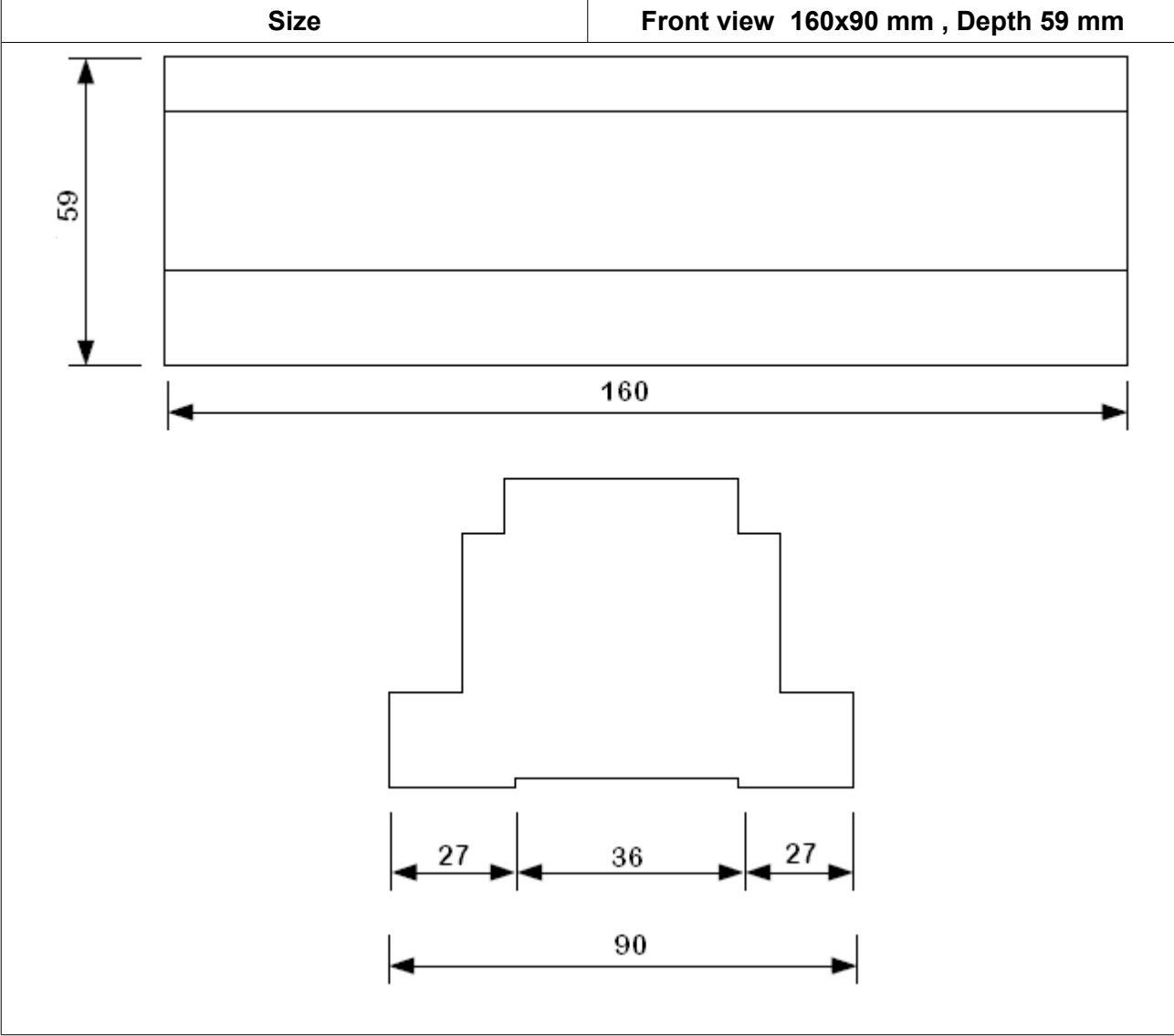



SOFTWARE CHARACTERISTICS	
Programming Languages	AWL / Ladder
Timers	64 timers with 16 bits and resolution 1/100 sec . 32 configurable timers one by one like excitation delay or disexcitation delay and 32 only excitation timers . 8 timers free running with 1 msec resolution enabled one by one with system flag .
Counters	32 counters with 16 bits configurable one by one like incremental or decremental .
Data Memory	2048
Developed Functions	<ul style="list-style-type: none"> - Week Programming - Recipe Management - Encoders Management - P.I.D. Temperature's Regulator - Forwarding/Reception SMS Messages
Memory area check in real time mode on data table (Debug)	●
Ladder's subroutines Import/Export	●
Contact and variable check in real time mode on ladder (Debug Online)	●