



ST1N 0840



8 channels

USER MANUAL

Internal version
rev. 1.2

20 March 2018

Index

1 GENERAL NOTES.....	3
1.1 Introduction.....	3
2 HARDWARE CHARACTERISTICS.....	6
2.1 CN1.....	7
2.2 CN2.....	8
2.3 CN3.....	8
2.4 CN4.....	10
2.5 CN5.....	11
2.6 Board size (with and without supporting box).....	11
2.7 Dip-switches.....	12
2.8 Fixing system of the naked board (without supporting box).....	12
2.9 Status led.....	12
2.10 RS485 communication cable.....	13
2.11 ST1N 0840.....	13
2.12 Information about wires and connectors.....	14
3 MEMORY MAP.....	15
3.1 Memory map description.....	17
3.2 Reading speed.....	18
4 ORDER CODES.....	18
5 CONTACTS.....	19

1.1 Introduction

The ST1N module to string control, allow to monitoring current and voltage generated by photovoltaic panels strings. For example is possible connect each other 32 PV panels at 36 V to each string channel, with positive pole connected each other. The negative pole of each string is brought to the dedicated input, like in the following picture :

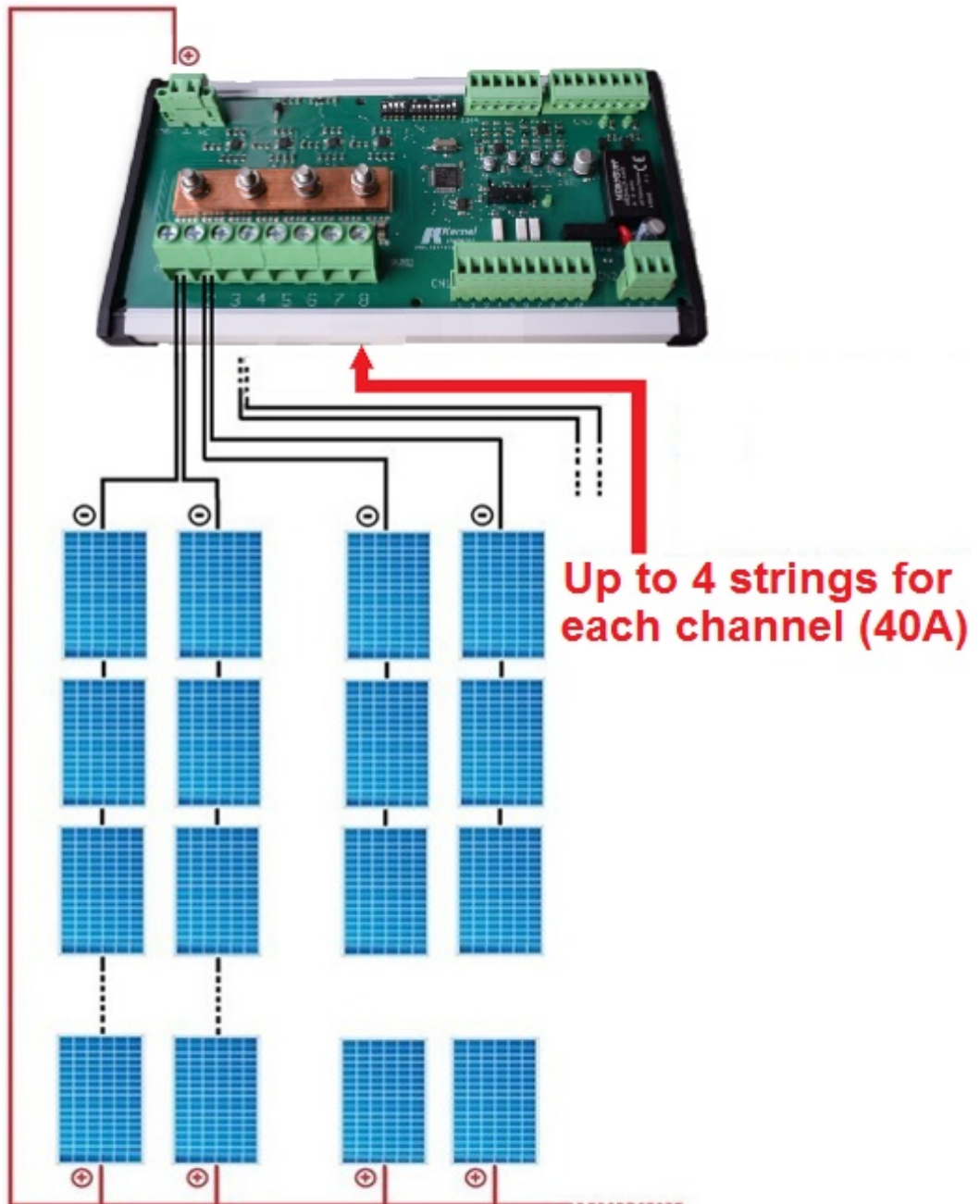

After the strings input connector, on the ST1N board there is a resistor, it is necessary to detect the current follow :

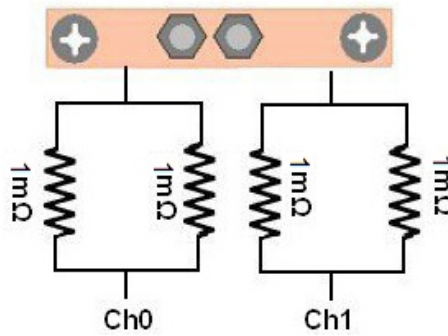

and finally a copper bar connect all the negative poles, thus creating a common 0 V.

The ST1N board also provides two digital inputs and an on-board sensor which allow to measure the temperature.

The digital inputs allows to detect the arrester state and the power disconnecter switch state.

Is possible communicate with the ST1N board through an RS485 serial port. Using **Modbus RTU protocol**, or with IEC 60870-5-101 protocol, is possible monitoring all the physical quantities measured (temperature, currents, voltage). Moreover is possible keep monitored the fuses status on the string box, through the reading of an internal register on memory map (DATA.30034).

STRING COMBINER BOX

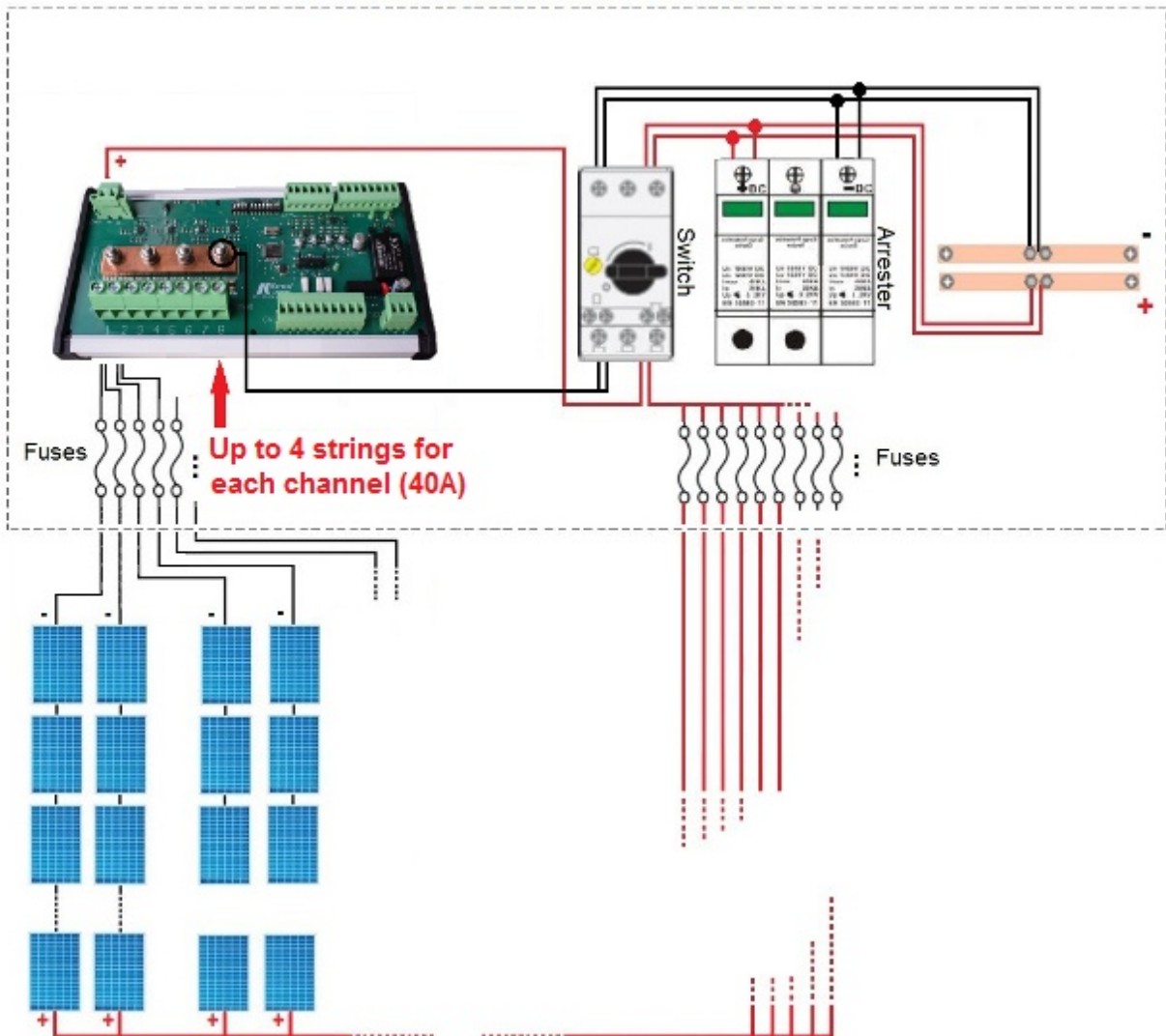

In the following image there are the “ST1N string controller” with all the wiring. Obviously isn't necessary connect all the specified devices, they are indicated to give a connection general idea.

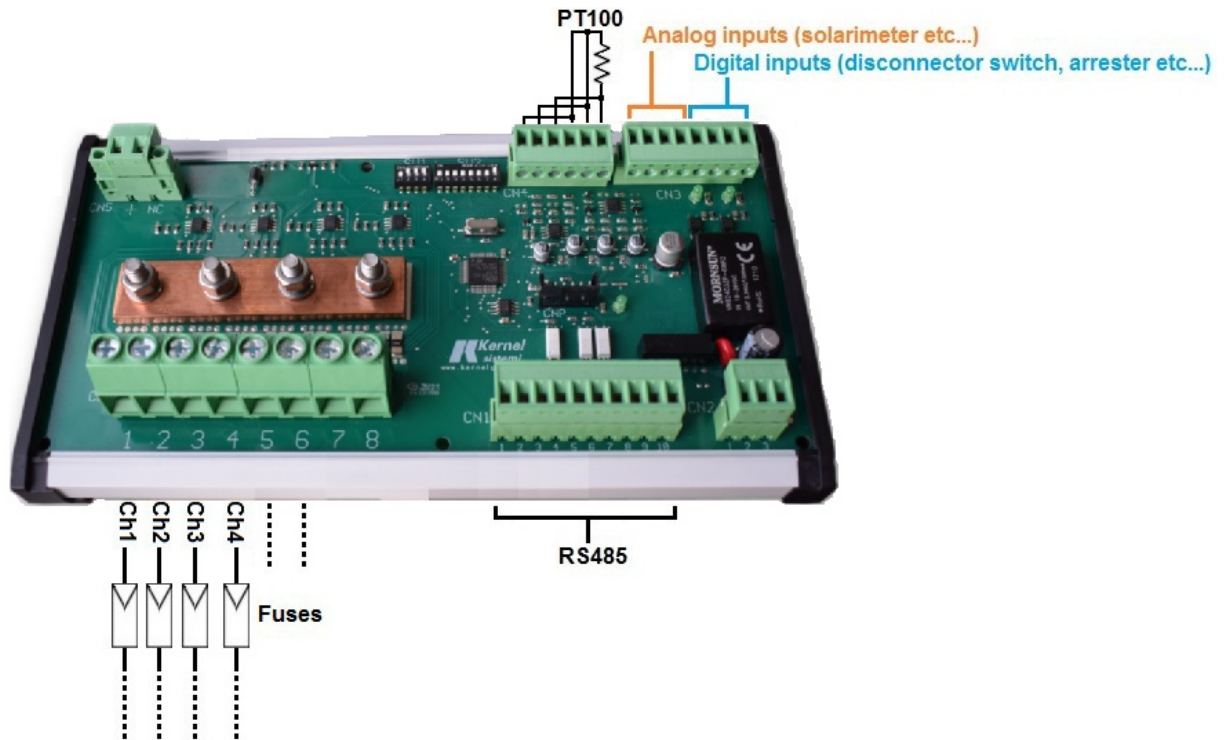

Microprocessor	STM32F303
Power supply	24 Vdc
Power consumption (W)	< 3W
Maximum number of monitored strings	8
Maximum common voltage	1500 V with precision better than 0,5 %
Max. current for each string	40
Range of measurement	0 ... 320 A
Current reading accuracy	Better than 0,15 %
Current reading precision	Typical 0,5 %
Communication	Modbus RS485 / RS487
Digital Inputs	Two digital inputs 24 Vdc PNP
Analog inputs	1 input PT100, 1 current input (0 ... 20 mA) and 1 voltage input (0 ... 10 V) for solarimeter + one on board temperature sensor to know the temperature inside the string box panel
Working temperature's range	From -20 to +80 °C
Temperature's drift 0 °C ÷ 70 °C	Better than 50 mA a 12,5 A
Working atmosphere	Without corrosive gas
ID Address	Defined by dip-switches
Size (naked)	108 x 228 mm
Size (with support)	128 x 233 mm

N°	Type of resources	Symbol	Terminal Block
1	PT100 inputs (from -20 to +120 °C) to temperature reading, with accuracy better than 1,5 %	T1	CN4
1	Sensor on board to switch board's temperature reading (accuracy better than 1,5 %)	/	On board
1	Analogic input from 0 to 10 V, typically to solarimeter connection	ADC2	CN3
1	Analogic input from 0 to 20 mA with accuracy better 1,5 %	ADC1	CN3
2	PNP digital inputs 24 Vdc, typically used to arrester connection, switches or other devices	INP0, INP1	CN3
1	RS485 serial port. This serial port is used to connect many "ST1N string controllers" into a network or to a PC. Is possible select the communication characteristics with a dip-switches on board (node address, baud rate, parity, and communication protocol, that may be Modbus RTU or IEC 60870-5-101). This COM is divided in two connectors in order to facilitate the wiring	SERIAL PORT	CN1
8	This board can manage the current reading of 8 strings until 40 A with typical precision of 0,5 %. and a temperature between -20 and +80 °C	Ch1...Ch8	CN6

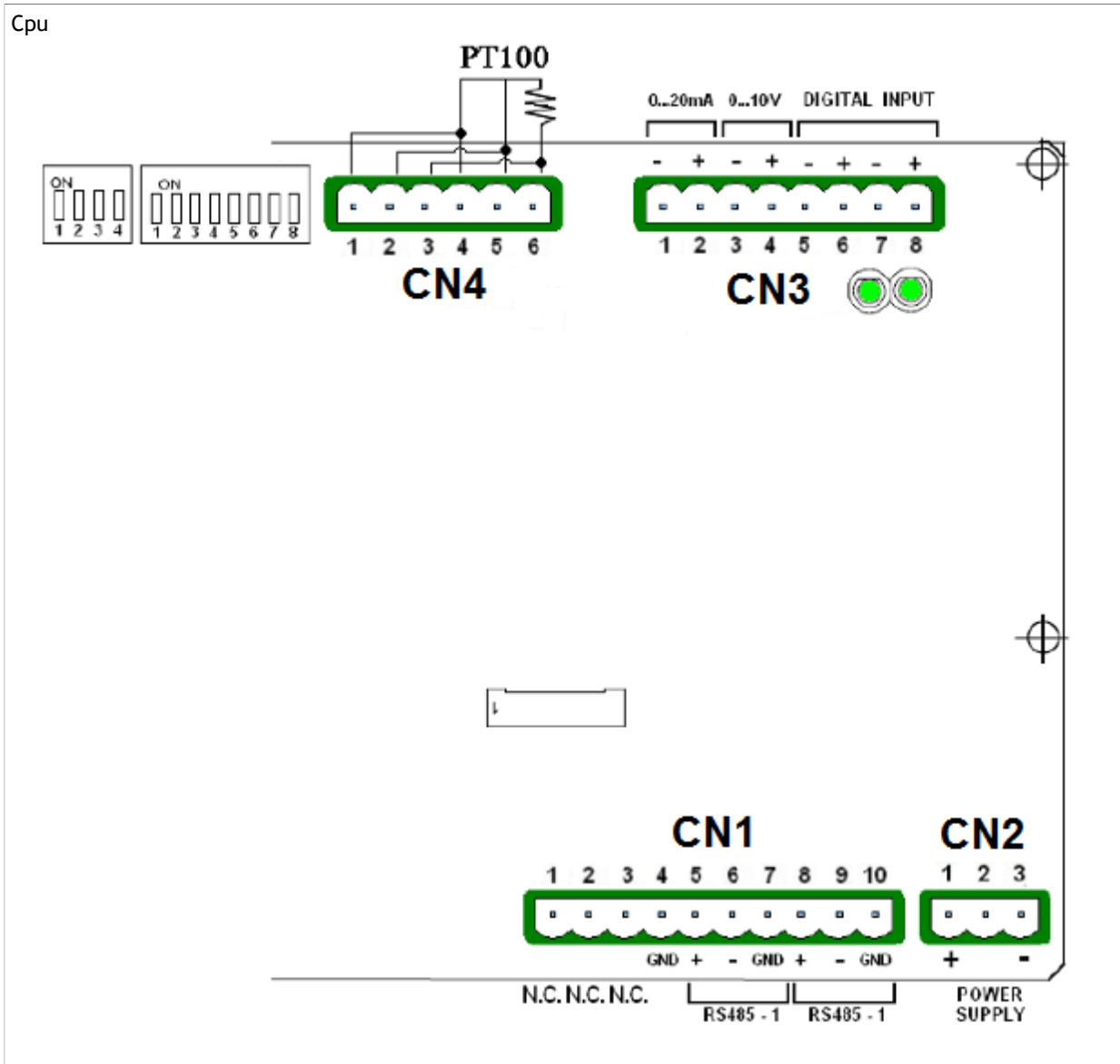

2.1 CN1

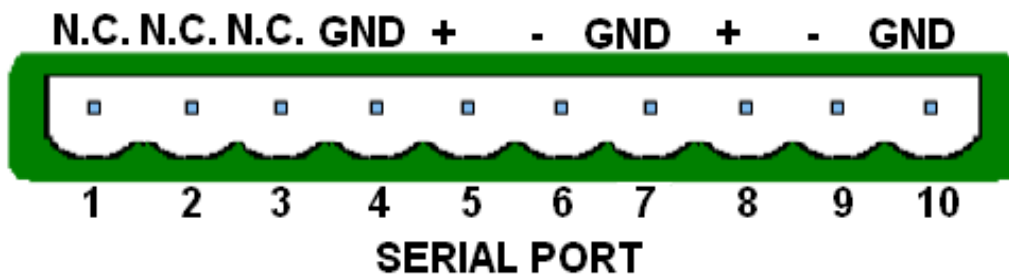

We've preferred insulate serial ports and power supply, the result is that we've an extremely reliable and accurate product compared to others on the market. On CN1 there is the splitted serial port RS485, 3 wires : plus, minus and GND.

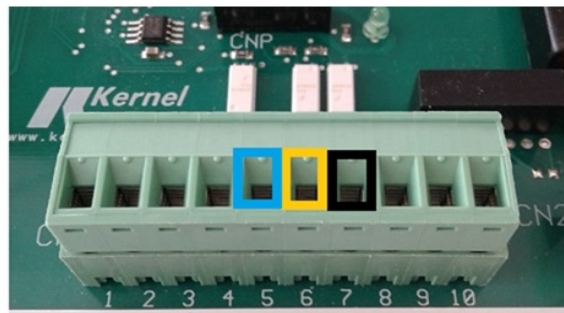
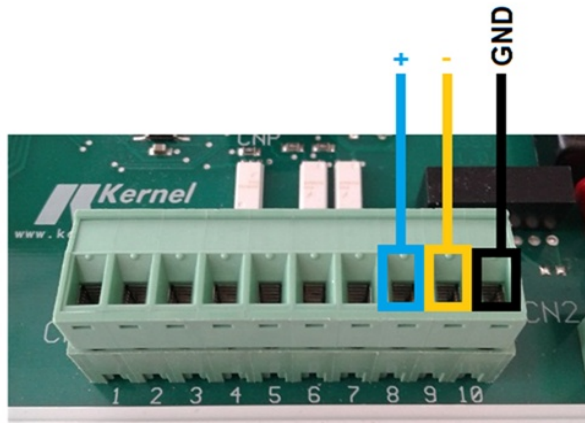

The serial port is split in the same terminal block to allow an easiest cabling.

2.2 CN2

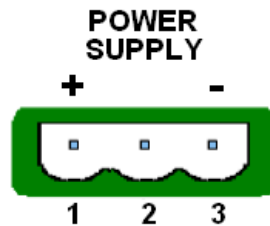

2.3 CN3

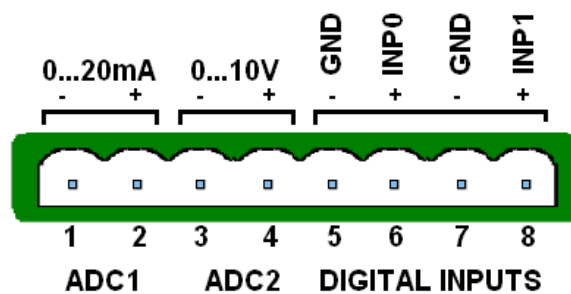

Is possible that there is a need to know when a switch (for example the general one) is ON or OFF, to this purpose there are two digital inputs PNP 24 Vdc on terminal block CN3. Each digital input status is indicated also by a led status on board. The connections are as below :

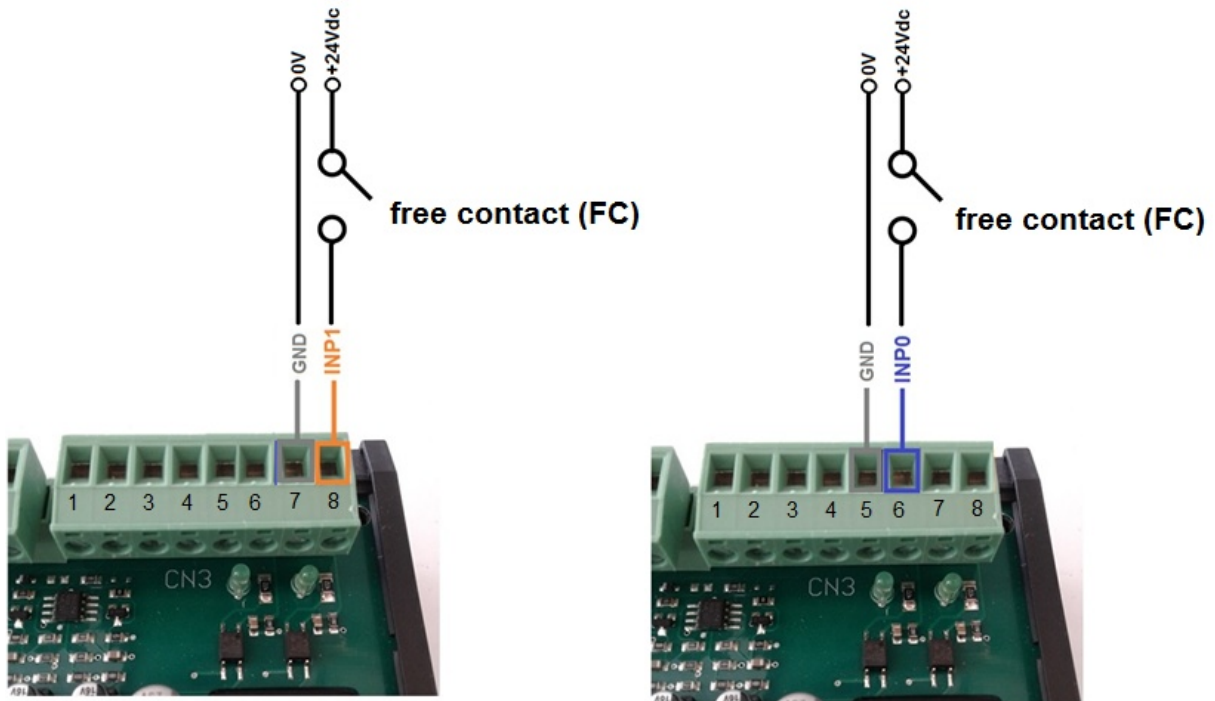

Inside the memory map the bits 0 and 1 of register DATA.30001 are the digital input status. To see bit number 1 of register DATA.30001, is necessary provide 24 Vdc between pin 7 and pin 8 (INP1).
 May be necessary connect a probe to a junction box, for example a pyrometer (to know the solar irradiation). To this purpose there are two analog inputs : one which allow to connect a signal which can be from 0 to 20 mA and the other one which allow to connect a signal from 0 to 10 Vdc. The connection is as below :

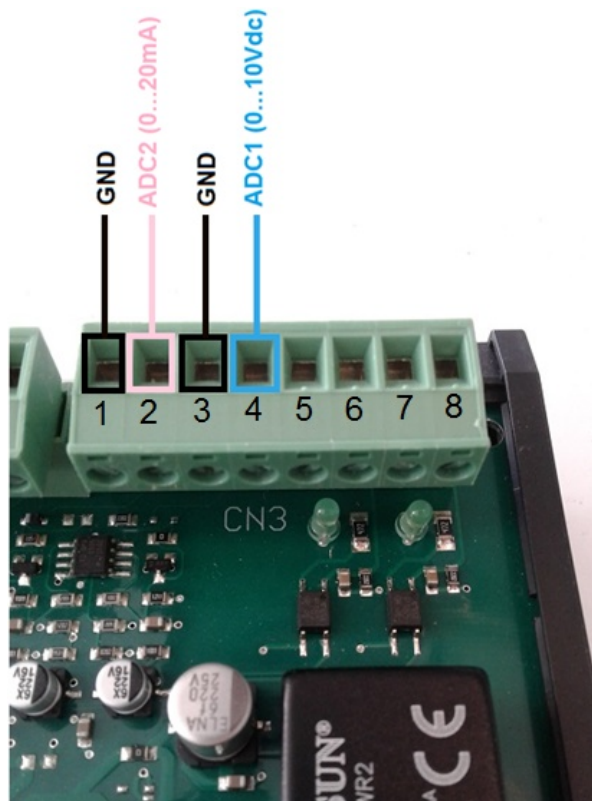

On register DATA.30042 and DATA.30043 you'll find a value between 0...1000 in order to the signal value (20 mA or 10 Vdc = 1000; 10 mA or 5 Vdc = 500; 0 mA or 0 Vdc = 0 etc...)

2.4 CN4

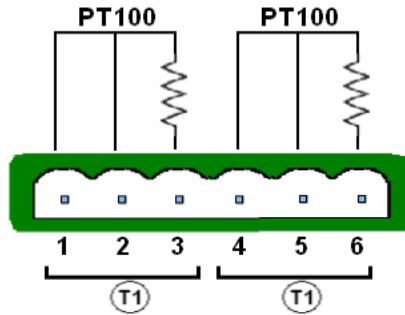

Is possible connect a PT100 to read the external temperature. The PT100 could be 2 or 3 wires, it will be connected in the following way to terminal block CN4. You'll find this temperature on register DATA.30044

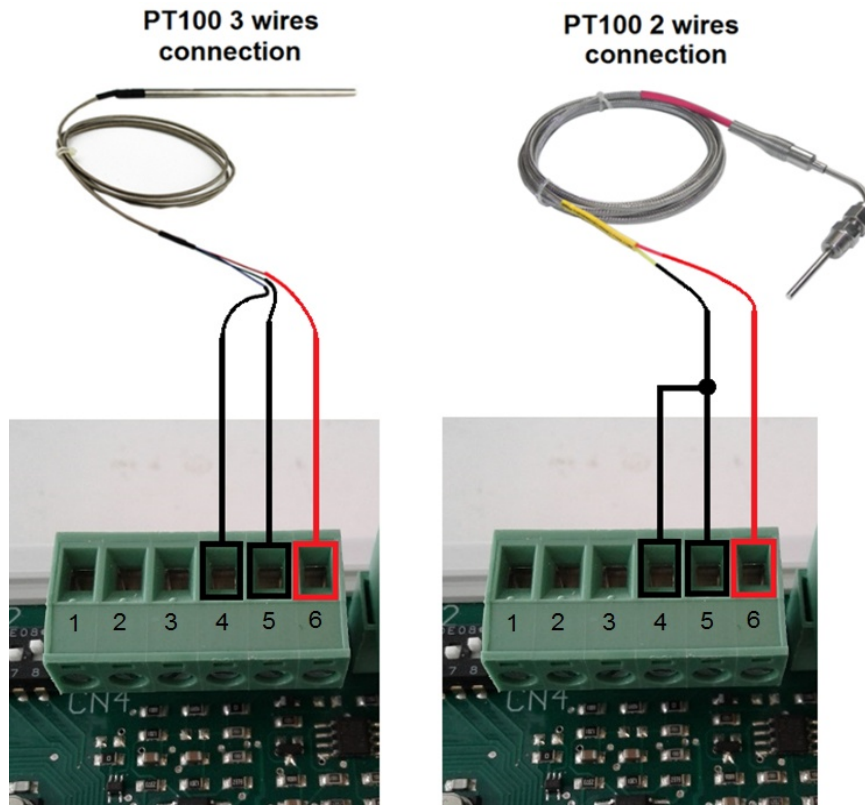

2.5 CN5

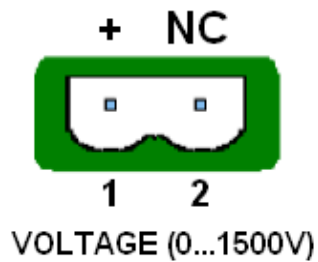

Kernel Sistemi s.r.l.

To be able to read the voltage (up to 1500 Vdc) is necessary connect the plus of all the strings (look the scheme above) to the CN5 connector. On this terminal block you must connect the pin which is highlighted in the below image with a red square. In this way you'll find the voltage value on the internal memory map in the register DATA.30040 :

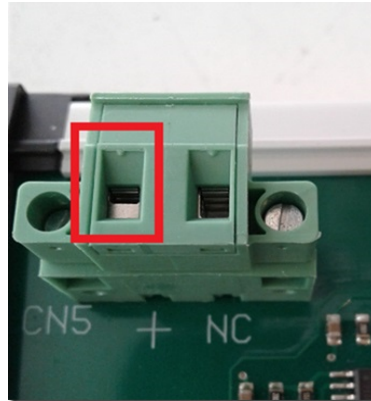

2.6 Board size (with and without supporting box)



ST1N 0840

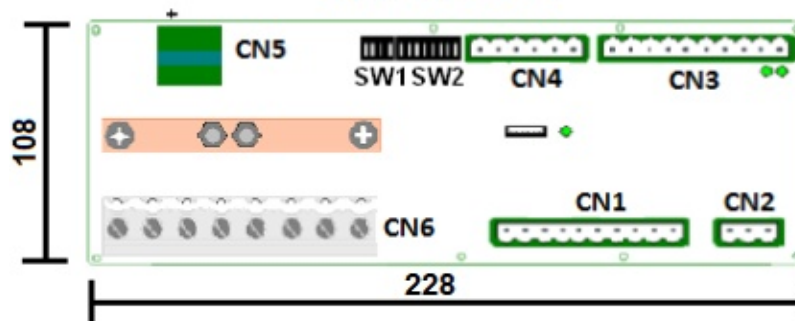

2.7 Dip-switches

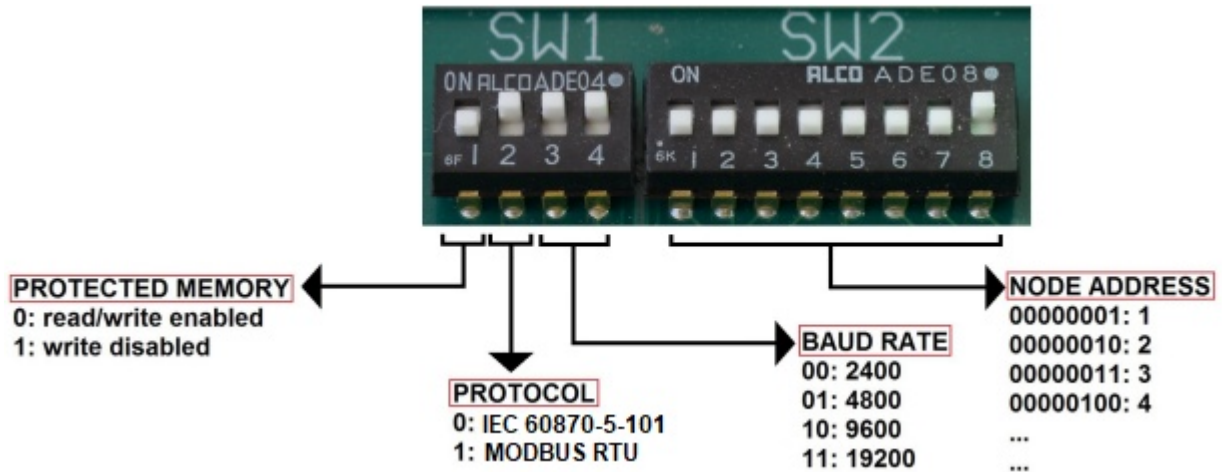

Some dip-switches examples :

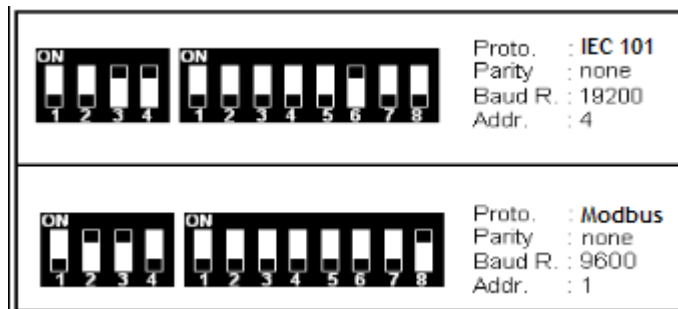

2.8 Fixing system of the naked board (without supporting box)

To fix the naked board (without case) is necessary use plastic spacers with dual clutch. The plastic spacers must be 4x20mm or 4x25mm (4mm is the hole diameter on the board). Look the below picture.



2.9 Status led

On the board there is a status led which with its blinking show the board status. There are two possible different blinking ways: blinking each 0,5 sec, or blinking faster. If the blinking is 0,5 sec ON and 0,5 sec OFF, it means the board is ready to communicate with an external device, instead if the blinking is faster than 0,5 sec, it means that the board is in test mode with all the dip-switch OFF. In this way the board isn't ready to communicate with an external device.

2.10 RS485 communication cable

Everything about the RS485 connection, must meet certain features :

Maximum cable length

it must be no longer than 1,2 Km (it means the entire line length, and not the connection between two nodes)

Maximum number of slaves

it's possible connect up to a maximum of one hundred slaves

Technical characteristics of the cable to use

It must be a three-wire cable 3 x 0.75mm

How to do the RS485 connection

The RS485 connection must be a three wires connection (TX+, TX- and GND) with a shielded cable. The cable shield must be leaved float, it means that the shield must be not connected neither one side nor the other one.

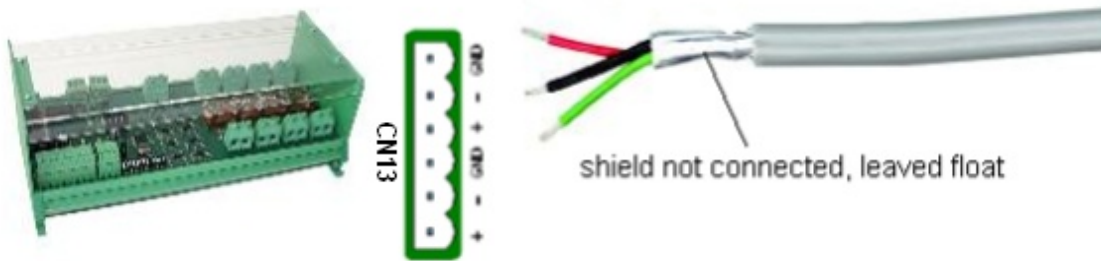

2.11 ST1N 0840

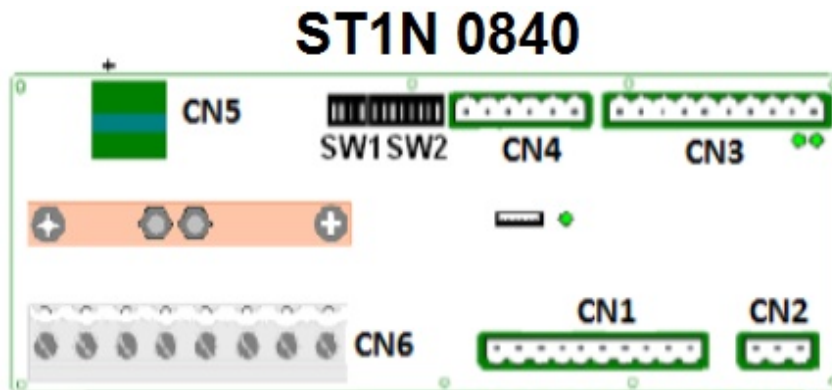

2.12 Information about wires and connectors



CHANNEL CONNECTOR

wire range : until 16 mm²
stripping length : 6 - 7 mm
torque : 0,85 N/m

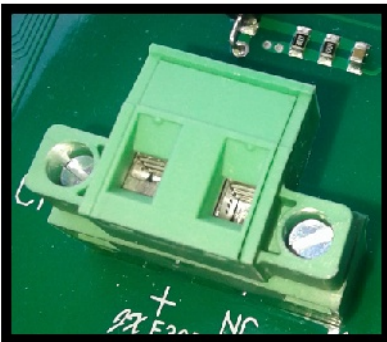

VOLTAGE CONNECTOR

wire range : AWG 12 - 14 ≈ 0,5 - 2 mm²
stripping length : 7 - 8 mm
torque : 5 Lb - In

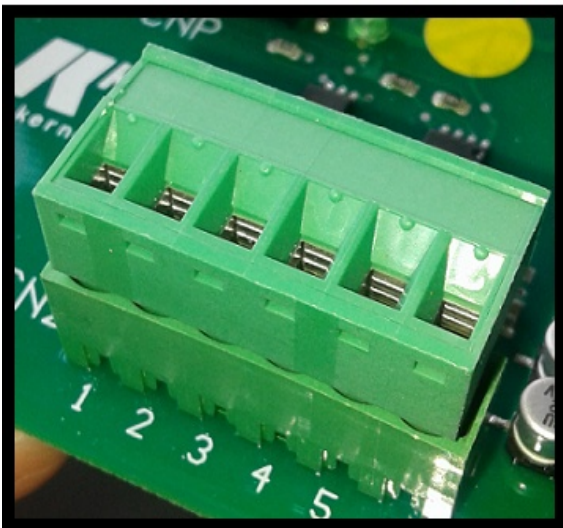

OTHER CONNECTORS (power supply, digital inputs etc...)

wire range : 2,5 mm²/0,34 - 2,5 mm²
stripping length : 7 - 8 mm
torque : 5 Lb - In



COPPER BAR BOLTS

torque : 2,2/2,5 N/m

The ST1N has the following memory map, it's made of 16 bits locations (1word) called "DATA". Because each DATA is composed by 16 bits, its maximum value will be 65535.

DATA.30001	Inputs
DATA.30002	Inst Curr Str_01 (mA [0...40000])
DATA.30003	Inst Curr Str_02 (mA [0...40000])
DATA.30004	Inst Curr Str_03 (mA [0...40000])
DATA.30005	Inst Curr Str_04 (mA [0...40000])
DATA.30006	Inst Curr Str_05 (mA [0...40000])
DATA.30007	Inst Curr Str_06 (mA [0...40000])
DATA.30008	Inst Curr Str_07 (mA [0...40000])
DATA.30009	Inst Curr Str_08 (mA [0...40000])
...	
DATA.30034	Fuse status (Ch1...Ch8)
...	
DATA.30040	Inst V_1 (V [0...1500])
...	
DATA.30042	Aux 1 (0 ... 10 V) [0...1000]
DATA.30043	Aux 2 (0 ... 20 mA) [0...1000]
DATA.30044	Inst T_1 (°C [-20...+120]) - PT100
DATA.30045	Inst T_2 (°C [-22,0...+83,0]) - on board
...	
DATA.30047	Sum of all currents / 10 (A)
DATA.30048	Power (W) - LSW
DATA.30049	Power (W) - MSW
...	
DATA.30052	RMS Curr Str_01 (average value on last 6 seconds)
DATA.30053	RMS Curr Str_02 (average value on last 6 seconds)
DATA.30054	RMS Curr Str_03 (average value on last 6 seconds)
DATA.30055	RMS Curr Str_04 (average value on last 6 seconds)
DATA.30056	RMS Curr Str_05 (average value on last 6 seconds)
DATA.30057	RMS Curr Str_06 (average value on last 6 seconds)
DATA.30058	RMS Curr Str_07 (average value on last 6 seconds)
DATA.30059	RMS Curr Str_08 (average value on last 6 seconds)
...	
DATA.30084	RMS V_1 (V [0...1500]) (average value on last 6 seconds)
...	
DATA.30086	RMS Aux 1 (0 ... 10 V) [0...1000] (average value on last 6 seconds)
DATA.30087	RMS Aux 2 (0 ... 20 mA) [0...1000] (average value on last 6 seconds)
DATA.30088	RMS Inst T_1 (°C [-20...+120]) (average value on last 6 seconds)
DATA.30089	RMS Inst T_2 (°C [-22,0...+83,0]) (average value on last 6 seconds)
...	
DATA.30091	RMS Sum of all currents (A) (average value on last 6 seconds)

Kernel Sistemi s.r.l.

DATA.30092	RMS Power (W) - LSW (average value on last 6 seconds)
DATA.30093	RMS Power (W) - MSW (average value on last 6 seconds)

...

DATA.40001	Set up PARITY mode : 1: none 2: even 3: odd
DATA.40002	Offset Curr Str_01
DATA.40003	Offset Curr Str_02
DATA.40004	Offset Curr Str_03
DATA.40005	Offset Curr Str_04
DATA.40006	Offset Curr Str_05
DATA.40007	Offset Curr Str_06
DATA.40008	Offset Curr Str_07
DATA.40009	Offset Curr Str_08

...

DATA.40034	Answer Delay (msec)
DATA.40035	Time Com Active (1/10 sec.)
DATA.40036	Parity (1 = None, 2 = Even, 3 = Odd) = DATA.40001
DATA.40037	Fuse Threshold

...

DATA.40040	Offset V_1
DATA.40041	Not used
DATA.40042	Offset Aux_1
DATA.40043	Offset Aux_2
DATA.40044	Offset T_1
DATA.40045	Offset T_2

...

DATA.40052	Gain Curr Str_1
DATA.40053	Gain Curr Str_2
DATA.40054	Gain Curr Str_3
DATA.40055	Gain Curr Str_4
DATA.40056	Gain Curr Str_5
DATA.40057	Gain Curr Str_6
DATA.40058	Gain Curr Str_7
DATA.40059	Gain Curr Str_8

...

DATA.40090	Gain V_1
DATA.40091	Not used
DATA.40092	Gain Aux_1
DATA.40093	Gain Aux_2
DATA.40094	Gain T_1
DATA.40095	Gain T_2

Notes:

Each “offset DATA” has 0 as default value. Each “gain DATA” has 1000 as default value. *The value 1000 means x1*, in this way, for example, is possible write 500 and make the value **x0,5**.

3.1 Memory map description

DATA.30001 : the first two bits of these register are the mirror status of the four digital inputs on the board (INP0 and INP1 on CN3). So if **DATA.30001** = 0000000000000011 [bin] = 3 [dec], it means that both two digital inputs are ON.

DATA.30002...DATA.30009 : these registers contains the current value of the current reading on each channel. It is in mA

DATA.30034 : the sixteen bits of **DATA.30034** show if each channel current reading is under 200 mA or not. This threshold represent the fuse status.

DATA.30040, DATA.30049 : these registers show the value of some readings as the temperatures (T1 and T2), voltage reading (on connector CN3 and CN4) etc...

DATA.30052, DATA.30059 : these registers contains the average value on last 6 seconds of the current reading. Obviously these values are more stable than the instantaneous values show in registers **DATA.30002 ... DATA.30009**

DATA.40001 : through this register is possible set the communication parity. The default value is zero, so “no parity”

DATA.40002, DATA.40009 : these are the offset registers. These registers (whose default value is 0) allow to add a constant value to the current reading. This allow to adjust a possible reading error. For example if **DATA.30002** show 2300 (it means that channel CH1 read 2,3 A), writing **DATA.40002** = 200 the new value of the reading will be **DATA.30002** = 2500 (it means that channel CH1 read 2,5 A).

DATA.40052, DATA.40059 : these are the gain registers. These registers (whose default value is 1000) allow to multiply a constant value to the current reading. This allow to adjust a possible reading error. For example if **DATA.30002** show 2300 (it means that channel CH1 read 2,3 A), writing **DATA.40052** = 1500 the new value of the reading will be **DATA.30002** = 3450 (it means that channel CH1 read 3,45 A, $2300 \times 1,5 = 3450$).

3.2 Reading speed

The analogic values of the currents, the voltage and the temperature are read simultaneously 10 times per second (100 msec scan time), then are inserted in it's own FIFO (a FIFO for each analogic value), 16 values deep. The value read from the board is the mobile mean of the FIFO, so it is the mean of the last 16 read values (1.6 sec), updated every 100 msec. This is done to make the analogic readout more stable and it is a good compromise between speed and readout stability.

The instant values of the analogic are temporary stored into a hidden memory area, not accessible to the COM port. The update time depend on the speed polling time of the SCADA and the communication baud rate.

The total time requested to read the board via com port is splitted into three times: *the query time*, *the latency time* and *the response time*.

The query time is the time needed by the SCADA to send the MODBUS query packet and depends on the baud rate (about 4 msec at 19200 baud rate).

The latency time is the time need by the board to process the query and prepare the answer, it is between 1 and 2 msec and it is independent on the baud rate.

The response time is the time needed byte the board to send the MODBUS answer packet, it's depend on the baud rate and on the number of registers read at a time, for a single register read at 19200 baud it is about 4 msec.

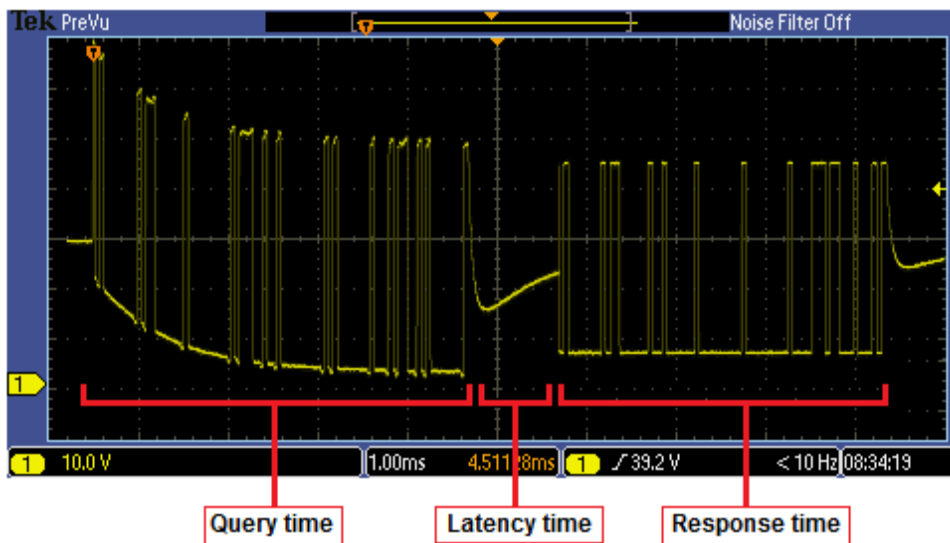

So at 19200 baud rate the total time needed to read a single register is about 10 msec., you have to add 1 msec every other register read, for example to read 16 registers with a single query will take $10 \text{ msec} + 15 * 1 \text{ msec} = 25 \text{ msec}$.



4

ORDER CODES

Here below the order codes :

CODE	DESCRIPTION	EXAMPLE PICTURE
ST1N 0840\NC	Device with support for din rail bar	
ST1N 0840\NK	Device without support for din rail bar	

GENERAL

Tel: 059 469978
website: www.kernelgroup.it
e-mail: info@kernelgroup.it

COMMERCIAL

Sig.ra Linda Mammi
Tel: 059 469978 Int. 207
e-mail: sales@kernelgroup.it
Skype: mammi.kernel

ADMINISTRATION

Sig.ra Paola Morandi
Tel: 059 469978 Int. 201
e-mail: amministrazione@kernelgroup.it
Skype: morandi.kernel

PURCHASING and PRODUCTION

Sig. Stefano Catuogno
Tel: 059 469978 Int. 204
e-mail: produzione@kernelgroup.it
Skype: catuogno.kernel

TECHNICAL OFFICE

Sig. Alessandro Muratori
Tel: 059 469978 Int. 205
e-mail: alessandro.muratori@kernelgroup.it
Skype: muratori.kernel

Support
Tel: 059 469978 Int. 209
e-mail: support@kernelgroup.it
Skype: support.kernel

Sig.ra Francesca Borghi
Tel: 059 469978 Int. 208
e-mail: francesca.borghi@kernelgroup.it
Skype: borghi.kernel

Sig. Morisi Luca
e-mail: luca.morisi@kernelgroup.it
Skype: morisi.kernel

Kernel Sistemi s.r.l. , via Vignolese n. 1138
41126 Modena - ITALY
Tel. 059 469 978 - Fax 059 468 874
www.kernelgroup.it